

Planning Committee

3rd June 2026

MC/26/0282

13 Park Avenue, Gillingham, ME7 4AS

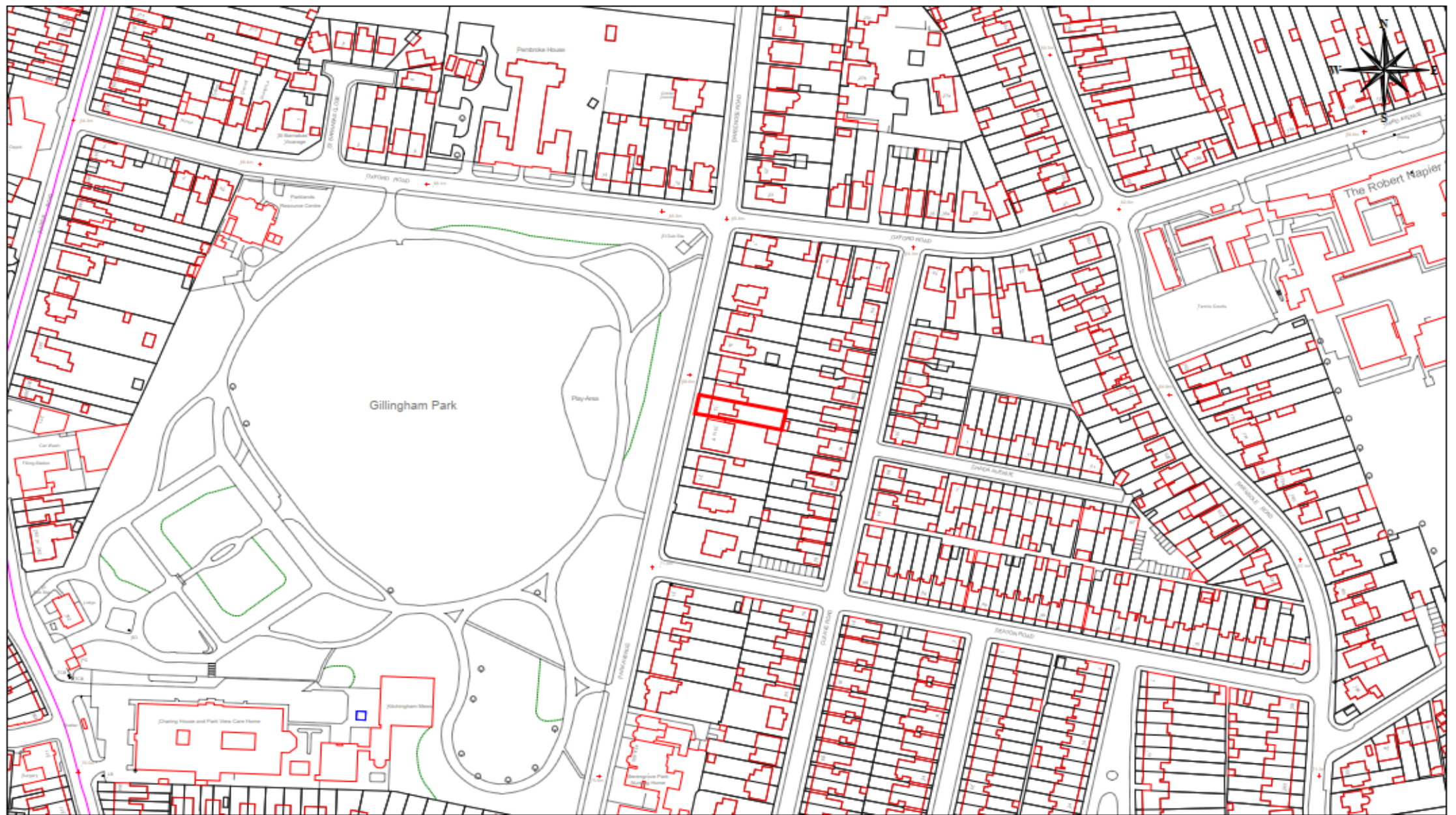

MC/26/0282 - 13 Park Avenue, Gillingham, ME7 4AS

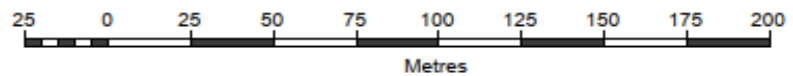

Site Location

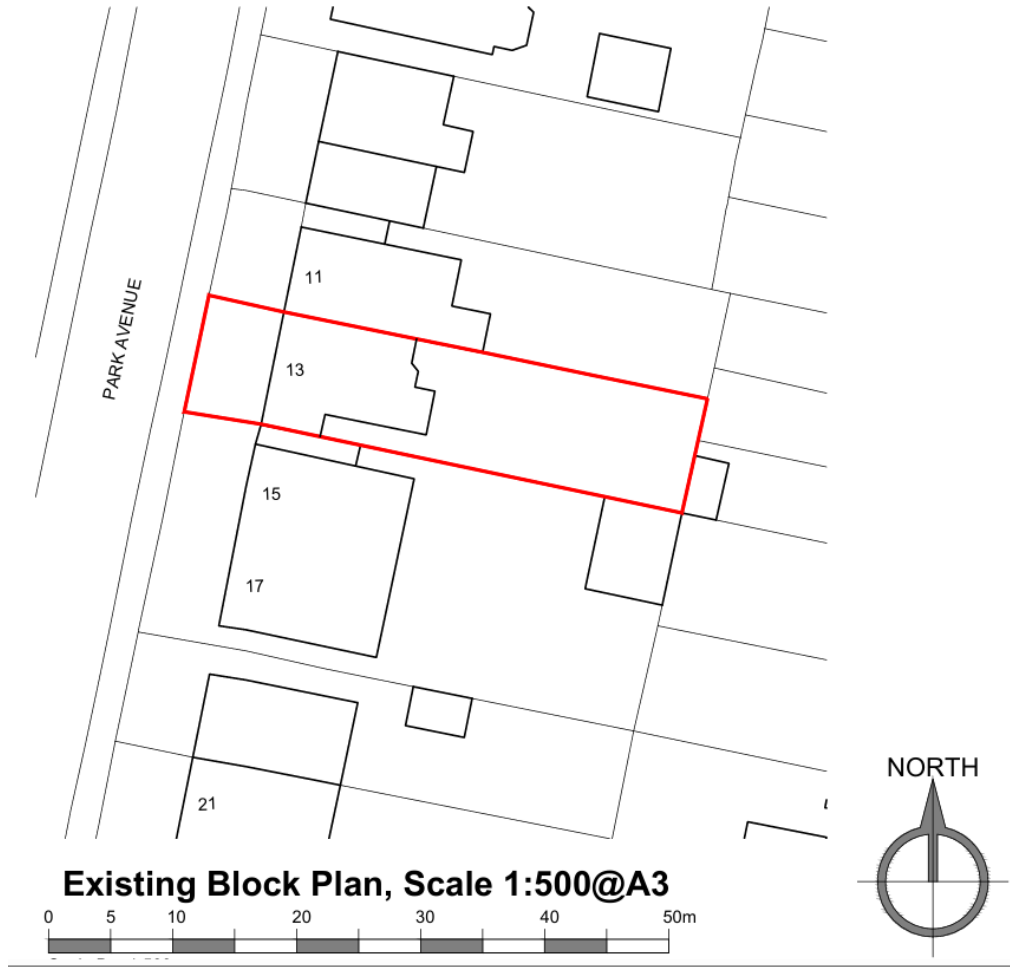

Parking Survey

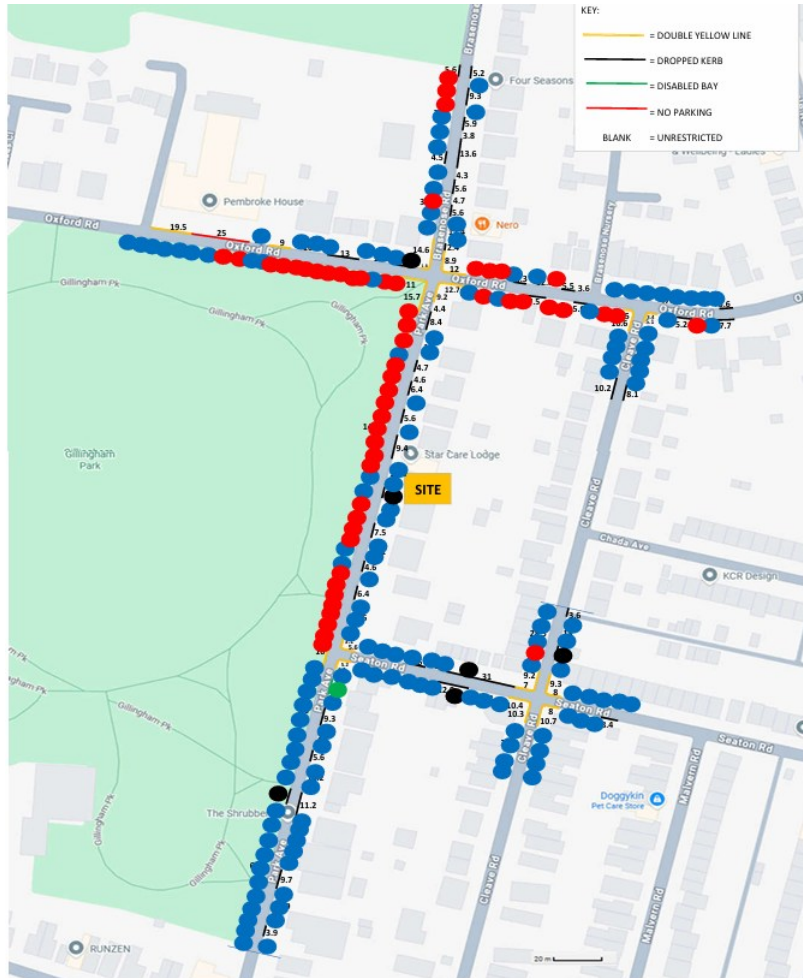

● PARKED CAR
● PARKED IN DISABLED BAY

● AVAILABLE SPACE ● PARKED ON DROP KERB

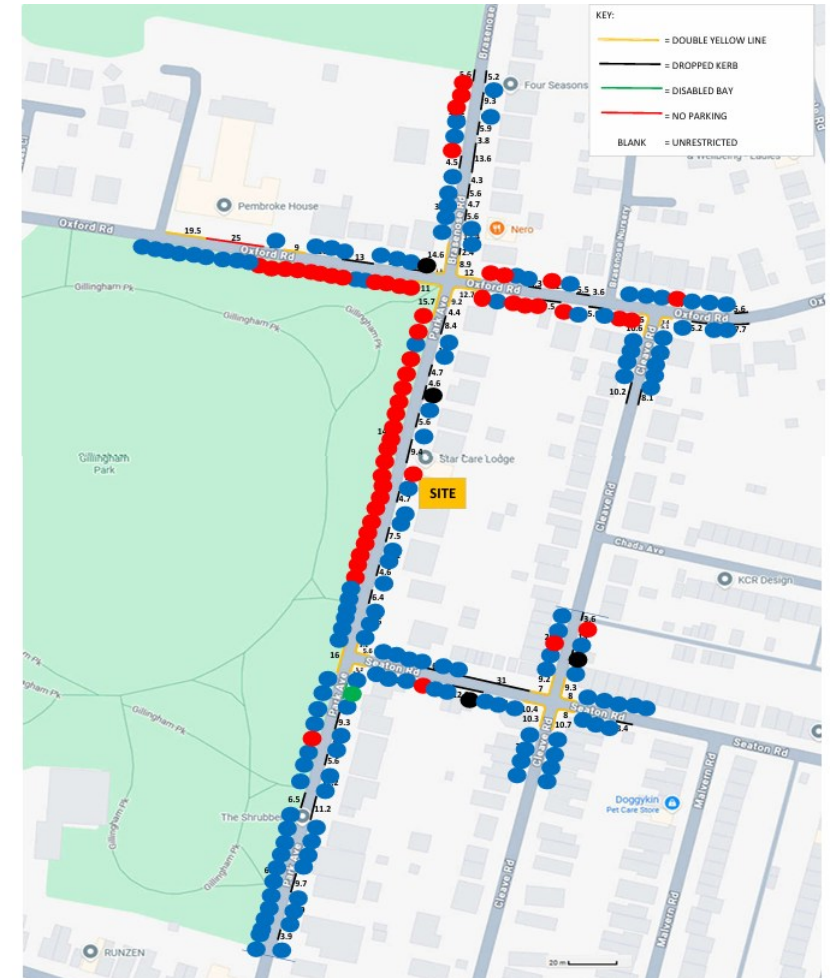

Site Photos



Site Photos



Existing Elevations



5 Existing West Elevation
1 : 100



7 Existing East Elevation
1 : 100



8 Existing South Elevation
1 : 100

Existing Floor Plans

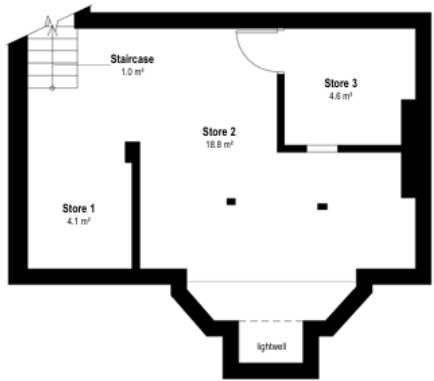

1 Existing Basement Floor Plan
1 : 50

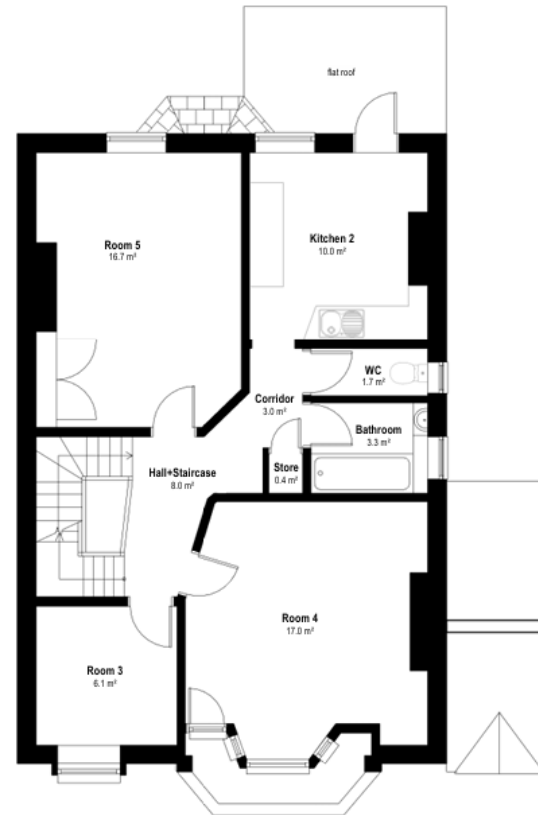
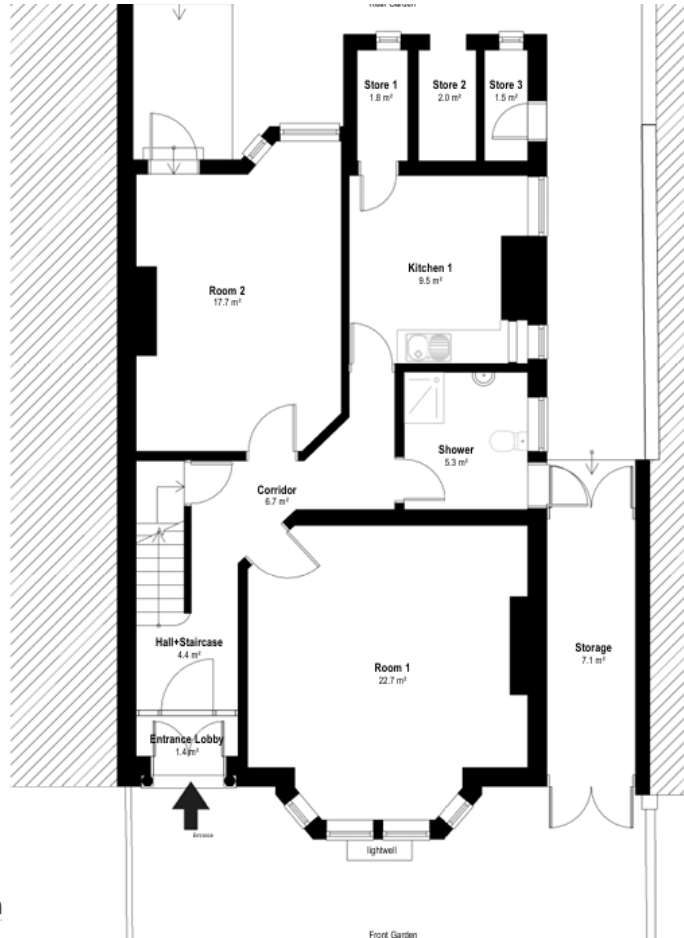

3 Existing First Floor Plan
1 : 50

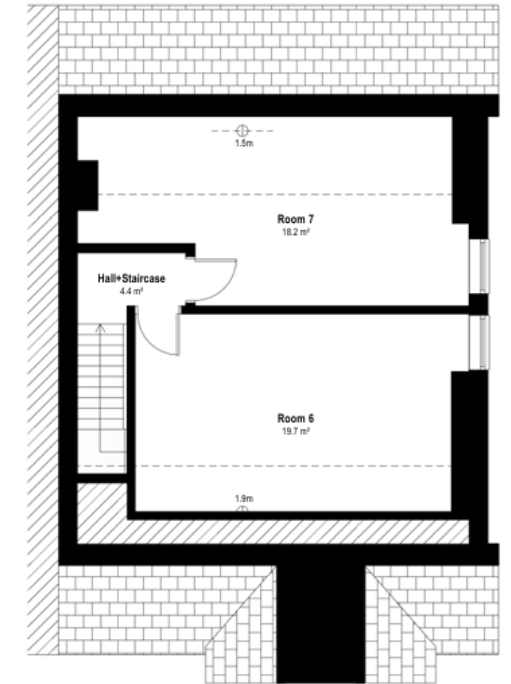

4 Existing Loft Floor Plan
1 : 50

Proposed Elevations



5 Proposed West Elevation
1 : 100

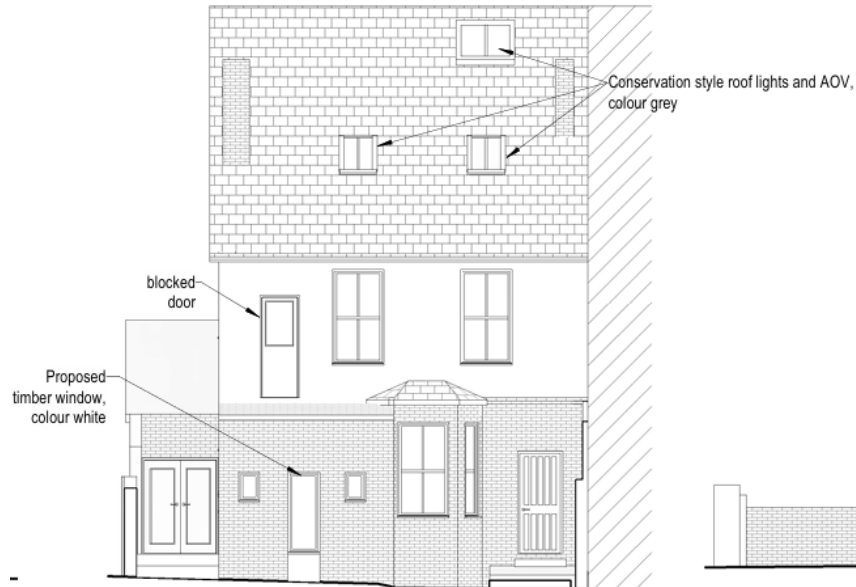

7 Proposed East Elevation
1 : 100



8 Proposed South Elevation
1 : 100

Proposed Floor Plans

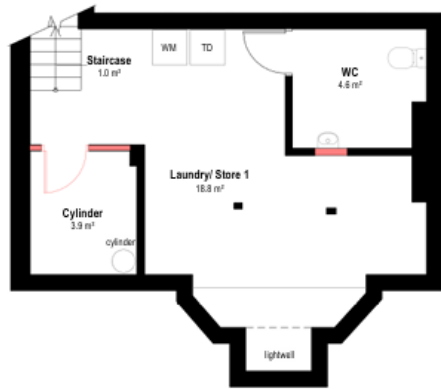

1 Proposed Basement Floor Plan
1 : 50

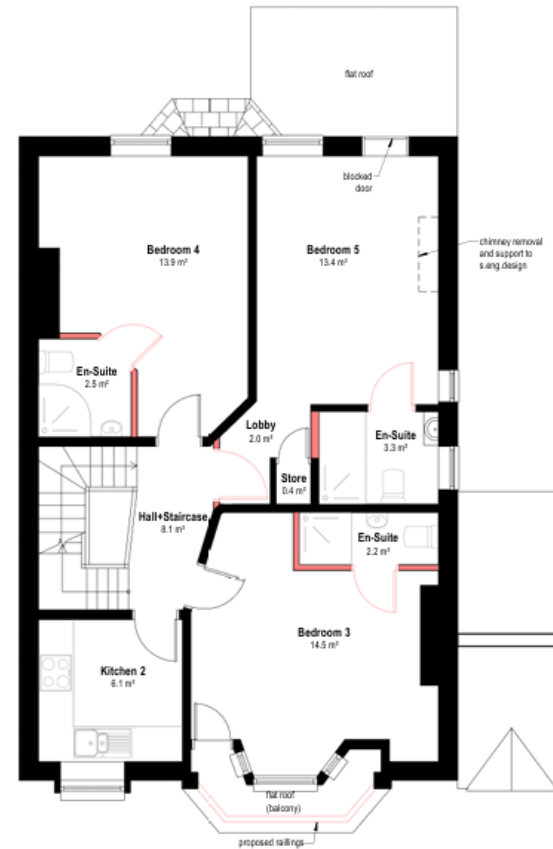
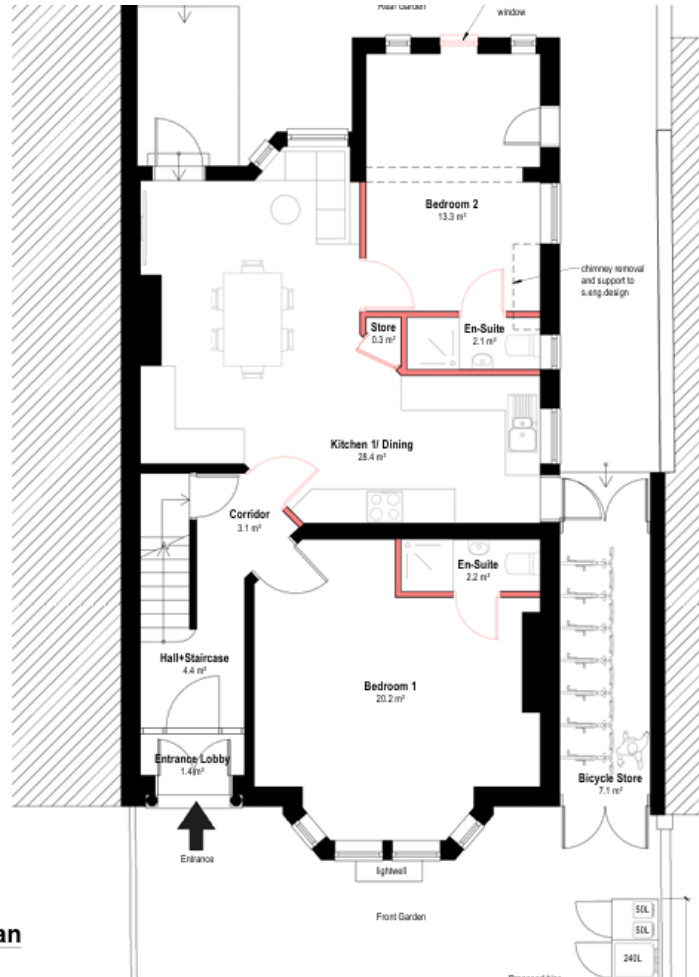

3 Proposed First Floor Plan
1 : 50

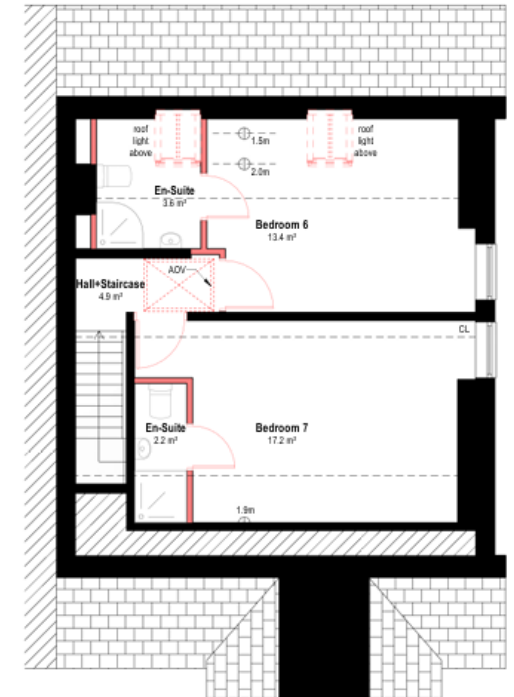

4 Proposed Loft Floor Plan
1 : 50

Section of Roof



1 Typical Section Through Loft Bedrooms
1 : 50

HMO Density

● - Application Property

● - HMO

○ - 500m Radius

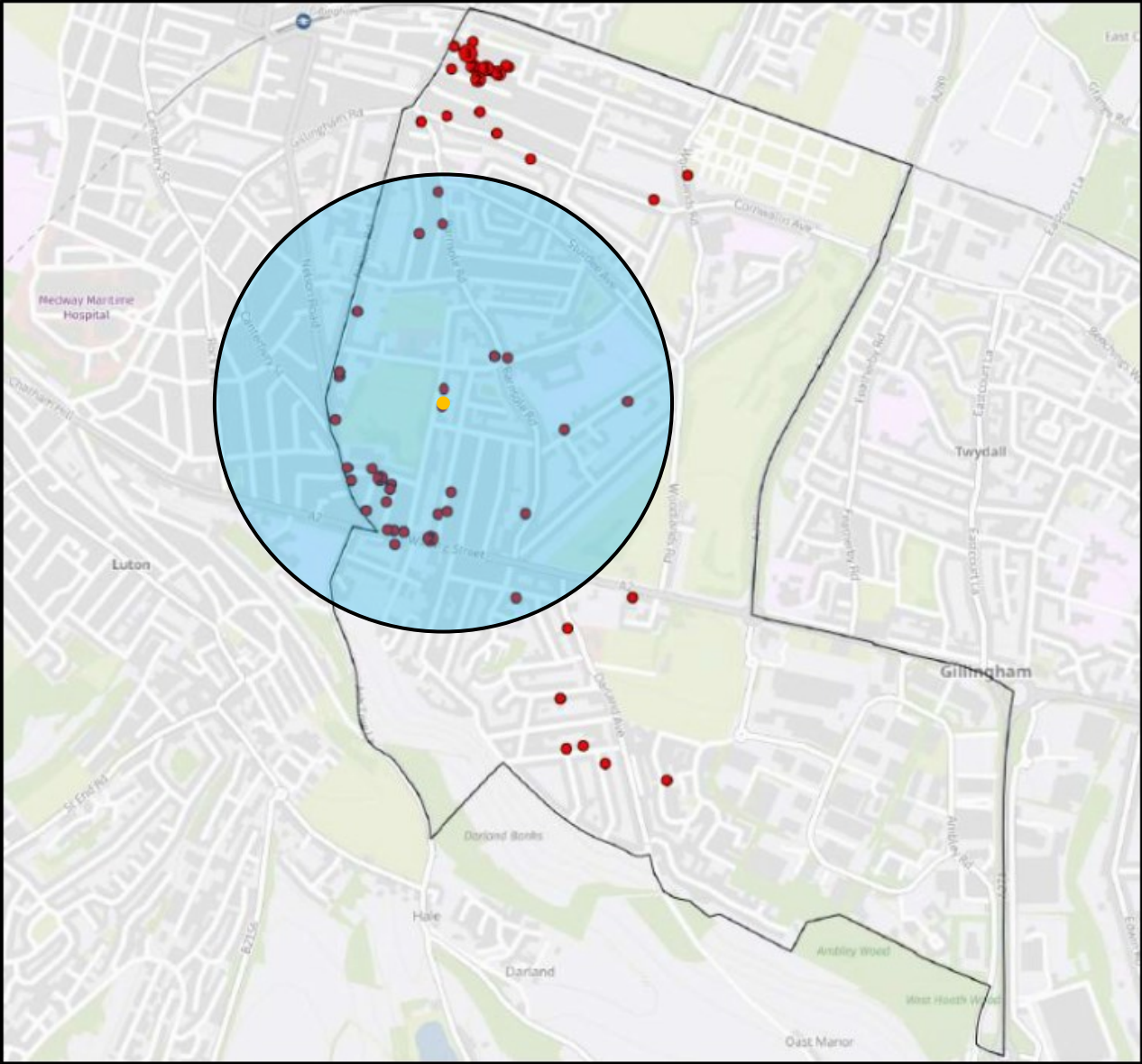

MC/26/0483

Ridgeway.11 Park Avenue, Gillingham, ME7 4AS



MC/26/0483 - Ridgeway, 11 Park Avenue, Gillingham, ME7 4AS

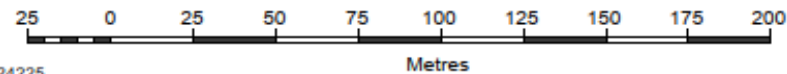

Site Location

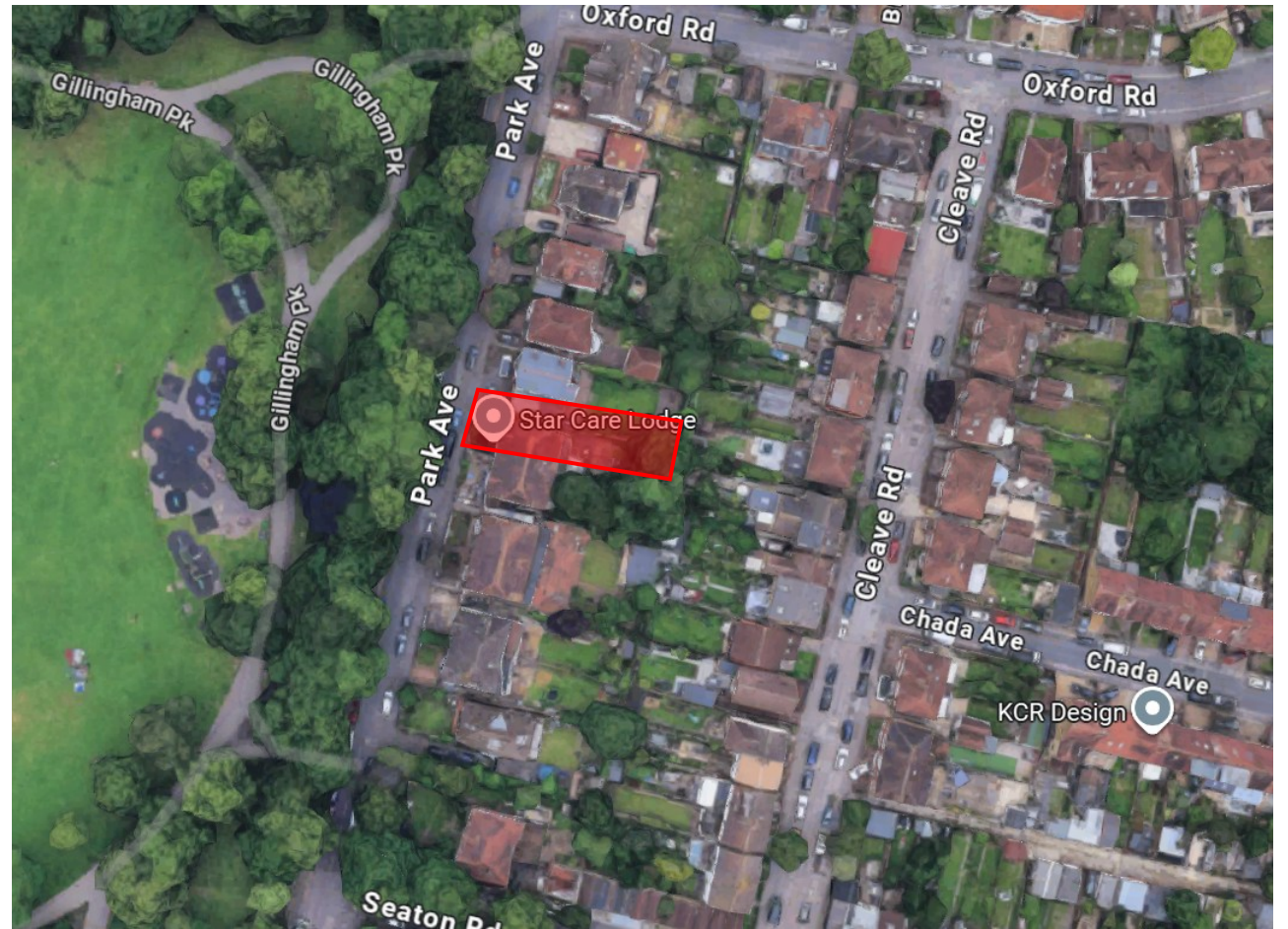

Site Photos



Site Photos



Existing Floor Plans

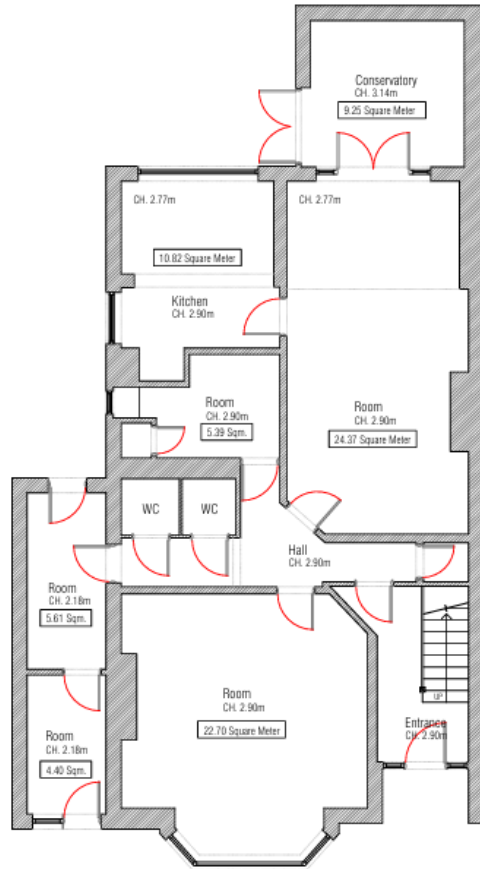

Ground Floor

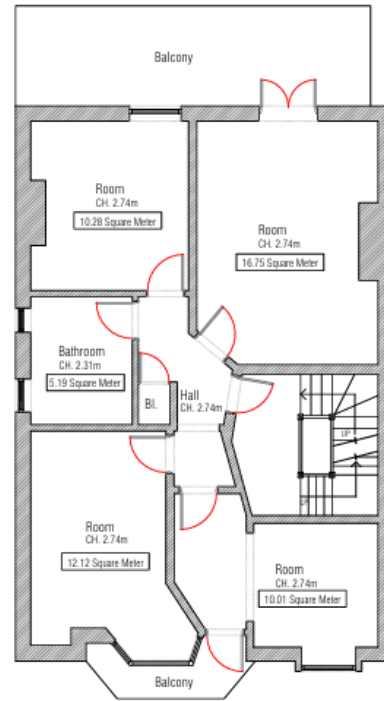

First Floor

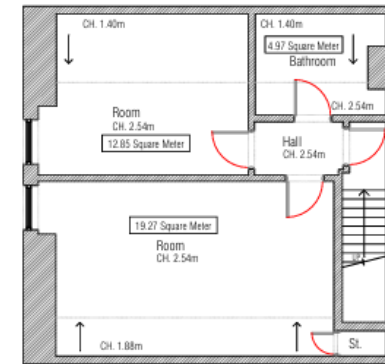

Loft Floor

Proposed Floor Plans

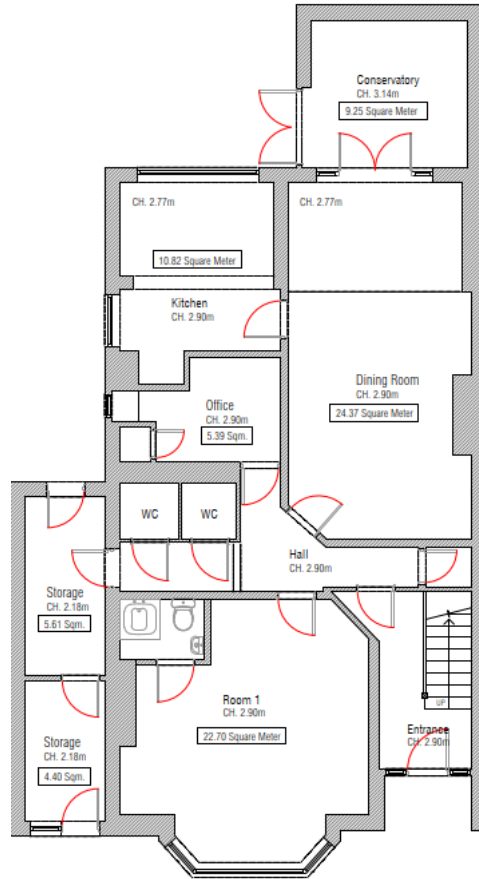

Ground Floor

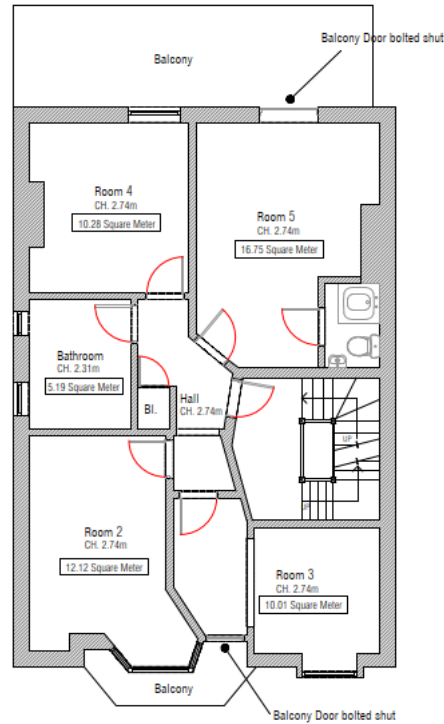

First Floor

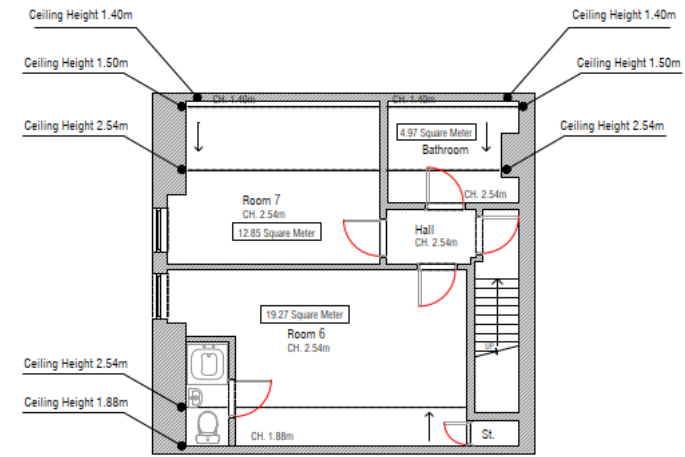

Loft Floor

HMO Density

● - Application Property

● - HMO

○ - 500m Radius

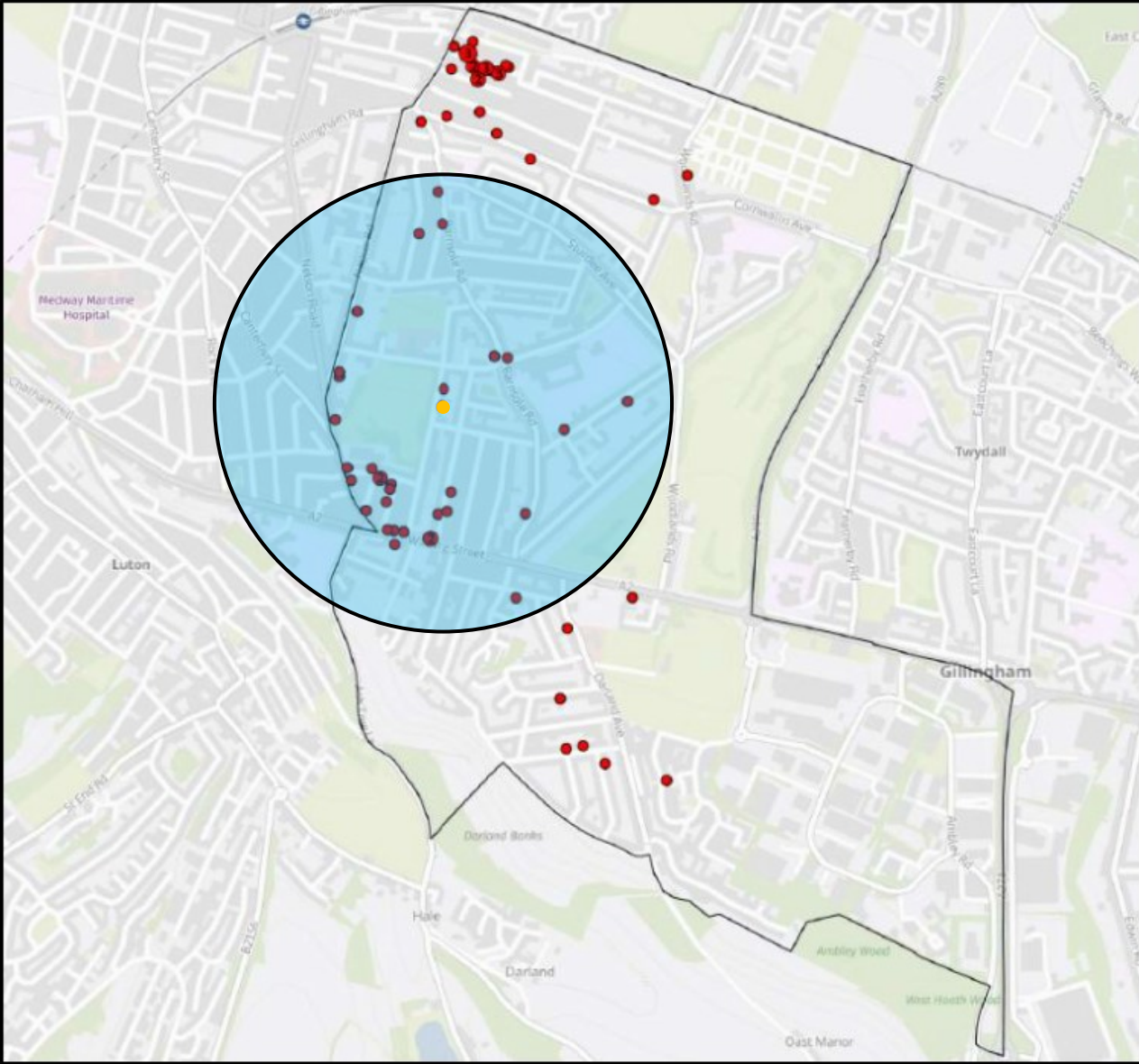

MC/26/0473

78 Ingram Road, Gillingham, ME7 1SH

Site Location



Site Photos



Site Photos



Existing Elevations



EXISTING
WEST ELEVATION

EXISTING
SOUTH ELEVATION

EXISTING
EAST ELEVATION

Existing Floor Plans

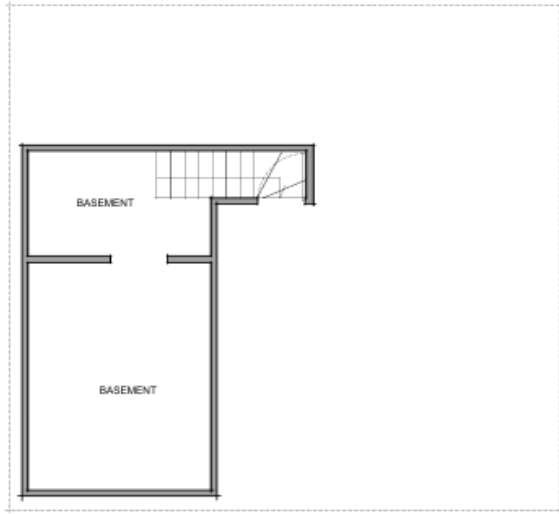

EXISTING
BASEMENT FLOOR PLANS

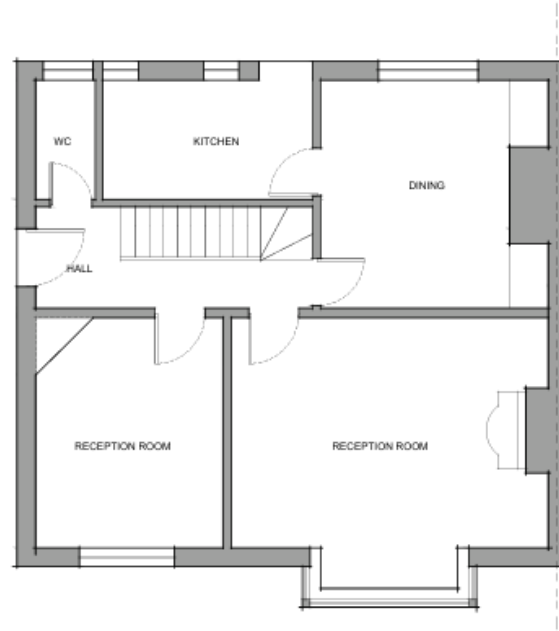

EXISTING
GROUND FLOOR PLANS



EXISTING
FIRST FLOOR PLANS

LDC Approved Elevations

MC/25/0874



PROPOSED
WEST ELEVATION

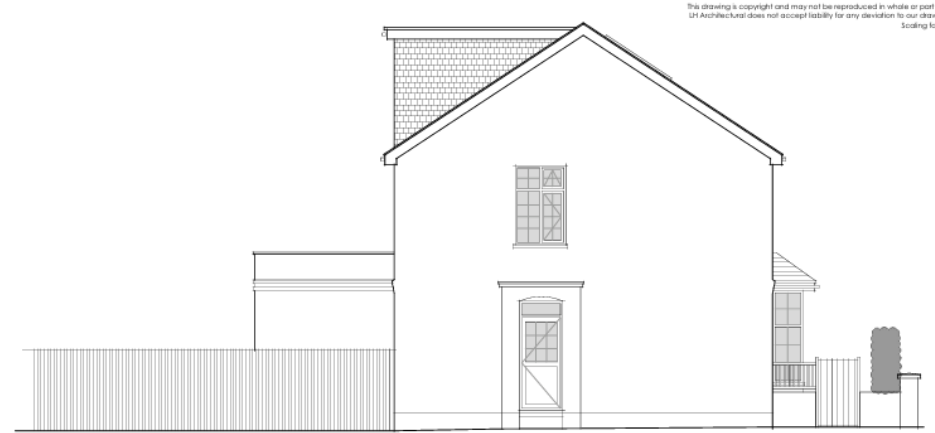

PROPOSED
SOUTH ELEVATION



PROPOSED
EAST ELEVATION



PROPOSED
NORTH ELEVATION

The drawing's copyright and may not be reproduced in whole or part with
UH Architectural does not accept liability for any deviation to our drawing
Scaling for pic

Rev	Date	Description
	dd-mm-yy	

Larger Homes Approved Elevations

MC/25/0871

This drawing is copyright and may not be reproduced
LH Architectural does not accept liability for any dev



PROPOSED
WEST ELEVATION



PROPOSED
SOUTH ELEVATION

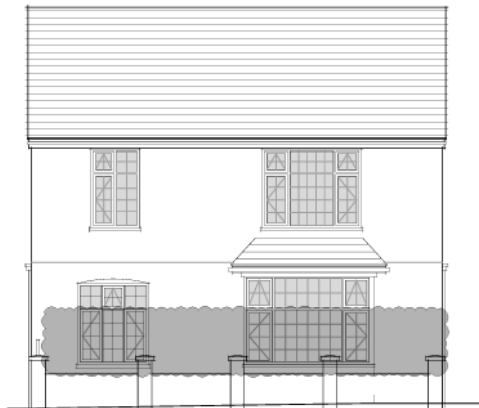

PROPOSED
EAST ELEVATION



PROPOSED
NORTH ELEVATION

Proposed Elevations



PROPOSED
WEST ELEVATION

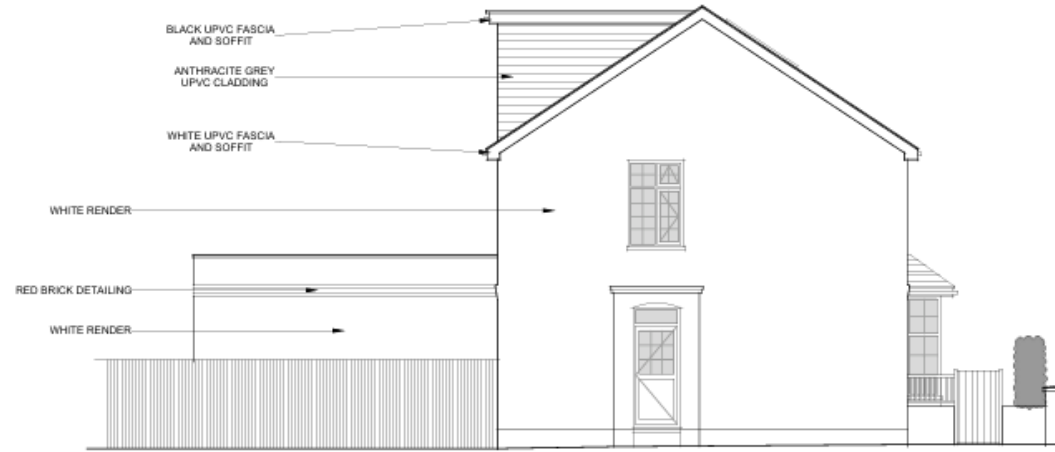

PROPOSED
SOUTH ELEVATION

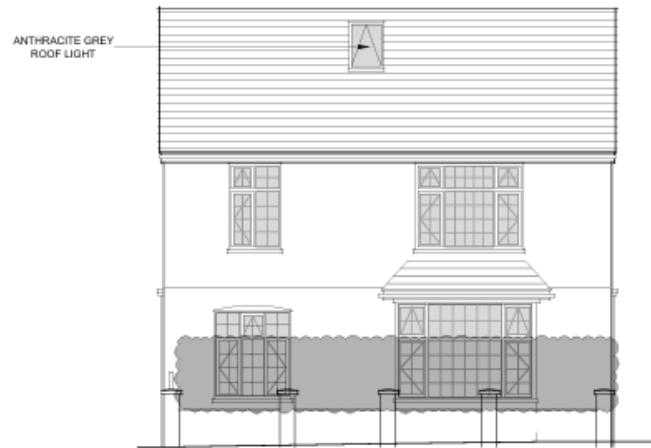

PROPOSED
EAST ELEVATION

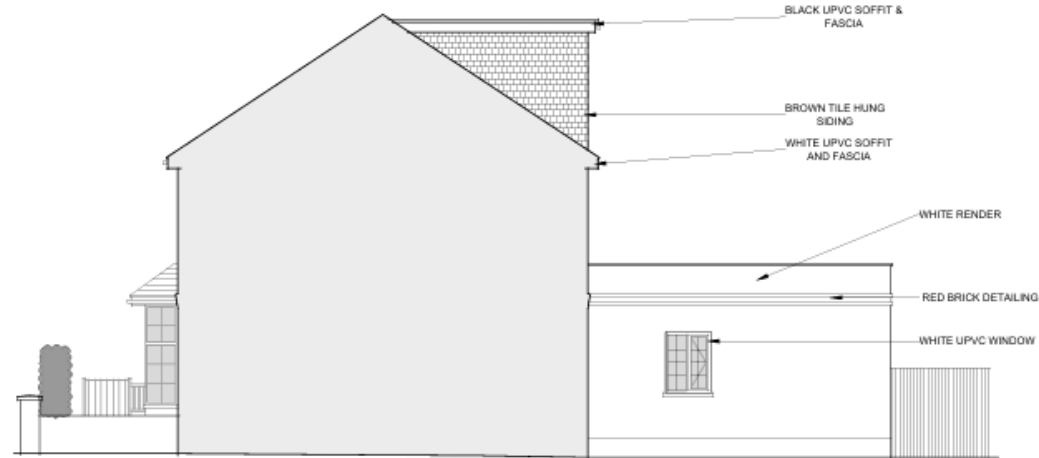

PROPOSED
NORTH ELEVATION

This drawing is copyright and may not be reproduced in whole or in part without the written consent of the Architectural firm. We do not accept liability for any deviation to our scale.

dd-mm-yy

Proposed Floor Plans

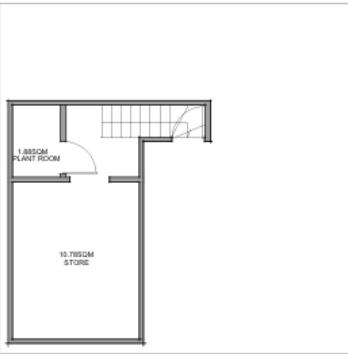

PROPOSED
BASEMENT FLOOR PLANS

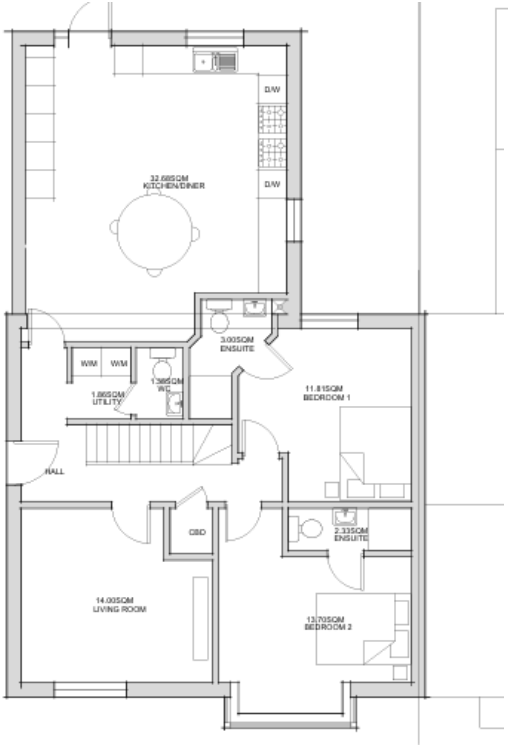

PROPOSED
GROUND FLOOR PLANS

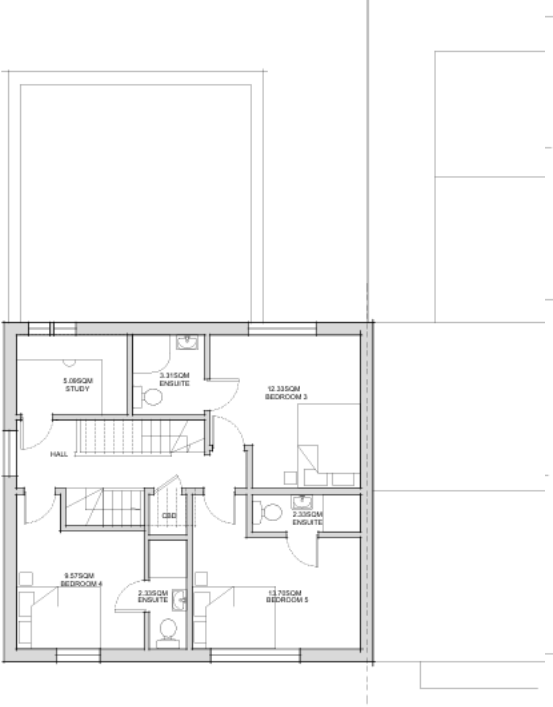

PROPOSED
FIRST FLOOR PLANS

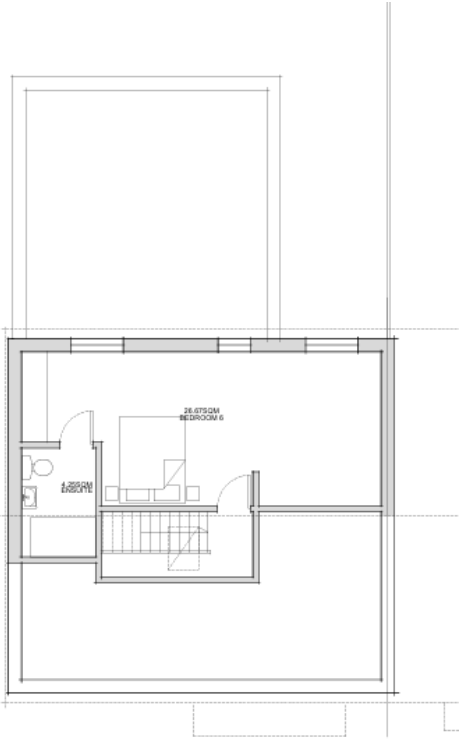

PROPOSED
LOFT FLOOR PLANS

Proposed Block Plan



PROPOSED

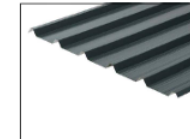
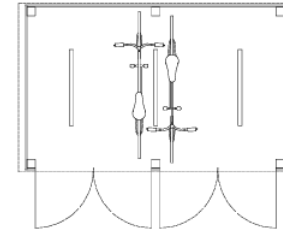

Grey profile polyester roofing

PROPOSED
PLAN & MATERIAL FINISH
 INDICATIVE SIZE - BUILDER TO CONFIRM ON SITE
 HEIGHT TO REMAIN AS INDICATED

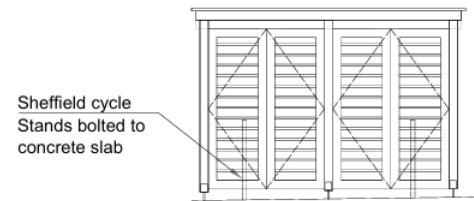

Sheffield cycle
 Stands bolted to
 concrete slab

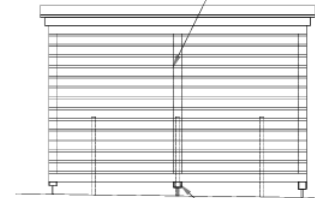
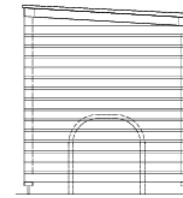

Hit & miss timber
 panelling to form
 sides of enclosure

Timber posts on
 saddle supports
 concrete into ground

PROPOSED
FRONT, SIDE & REAR ELEVATIONS
 INDICATIVE SIZE- BUILDER TO CONFIRM SIZE ON SITE.
 HEIGHT TO REMAIN AS INDICATED

HMO Density

● - Application Property

● - HMO

○ - 500m Radius

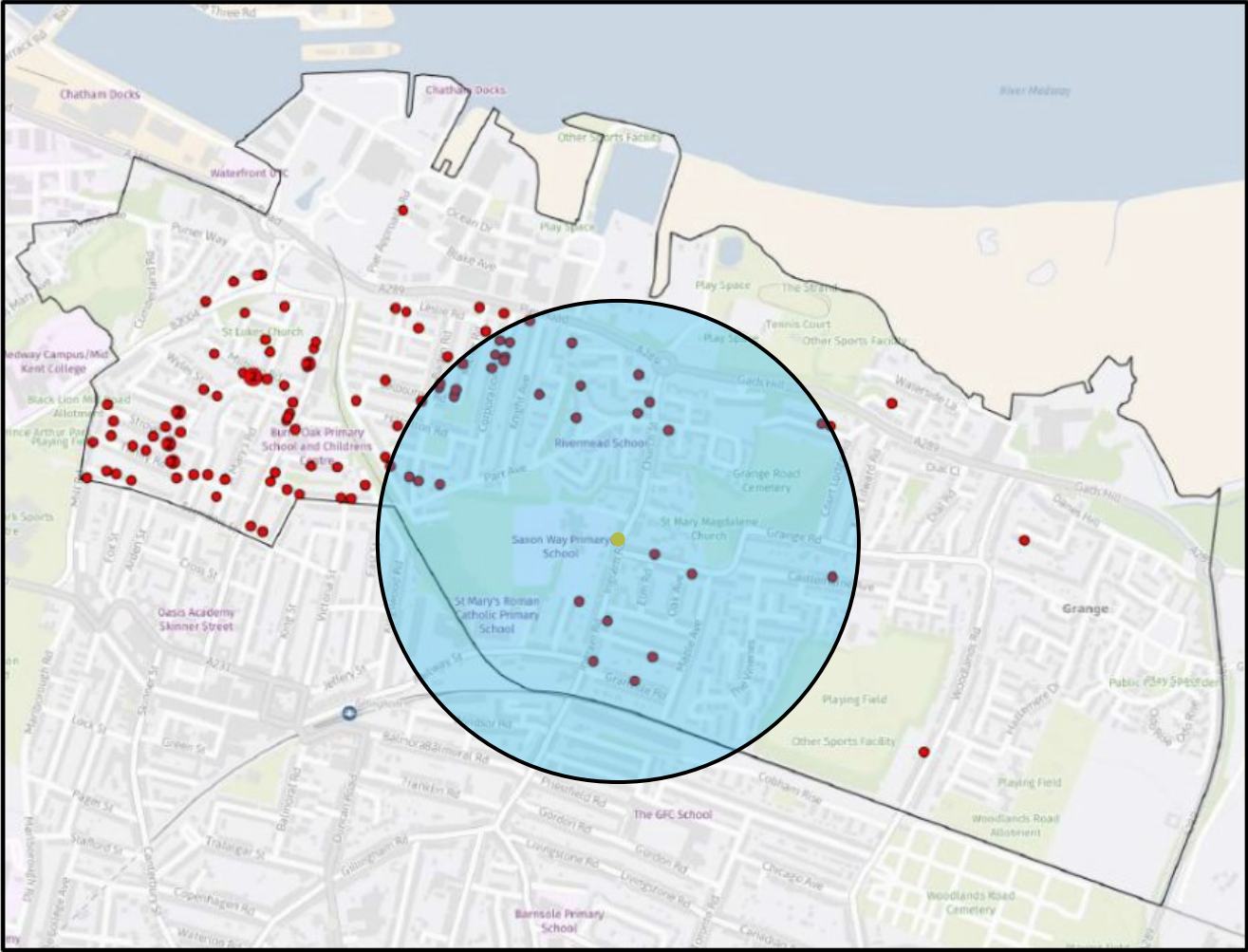

MC/26/0625

415 Canterbury Street, Gillingham, ME7 5LL

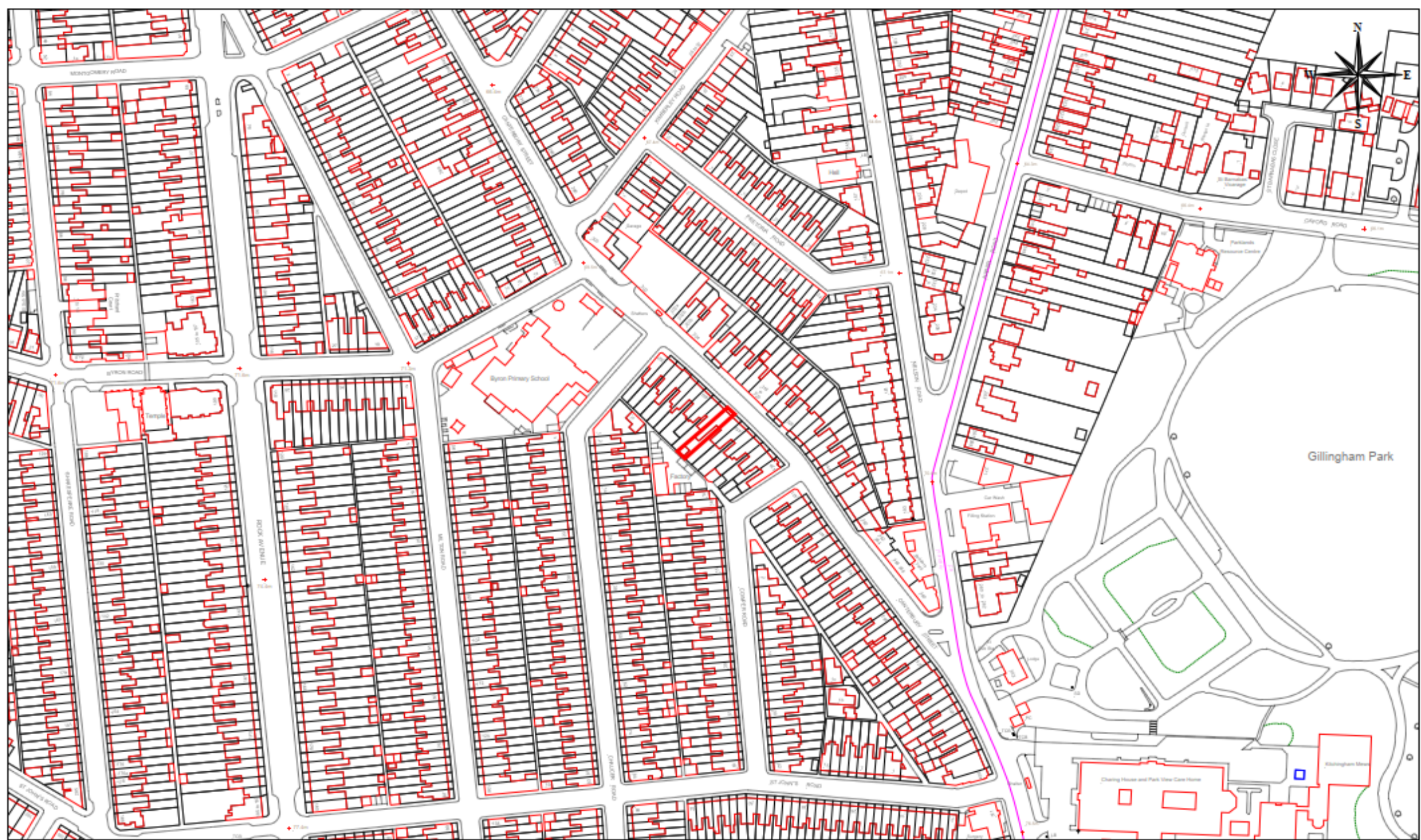

MC/26/0625 - 415 Canterbury Street, Gillingham, ME7 5LL

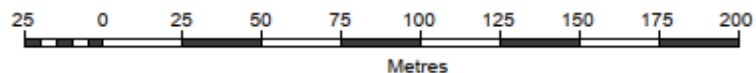

Site Location



Site Photos



Apr 02, 2026 12:00:40 pm

Site Photos



Existing Elevations



FRONT ELEVATION

SCALE 1:50

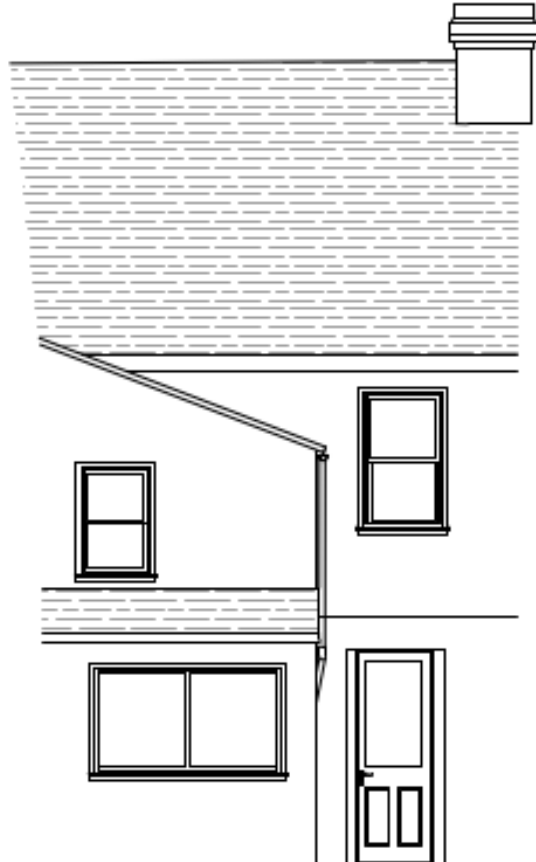

REAR ELEVATION

SCALE 1:50



SECTION A-A

SCALE 1:50

Existing Floor Plans

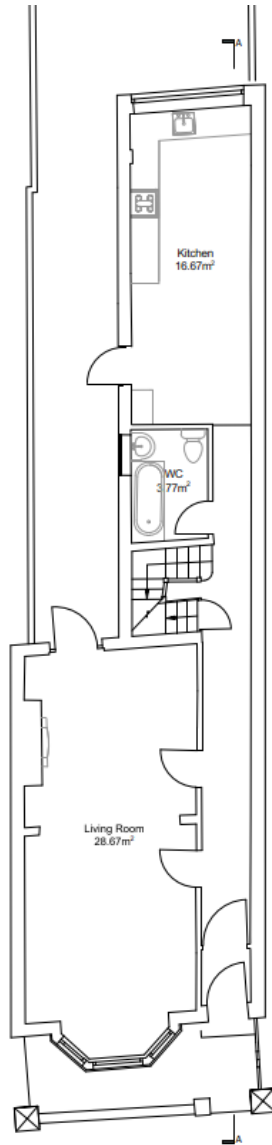

GROUND FLOOR PLAN
SCALE 1:50

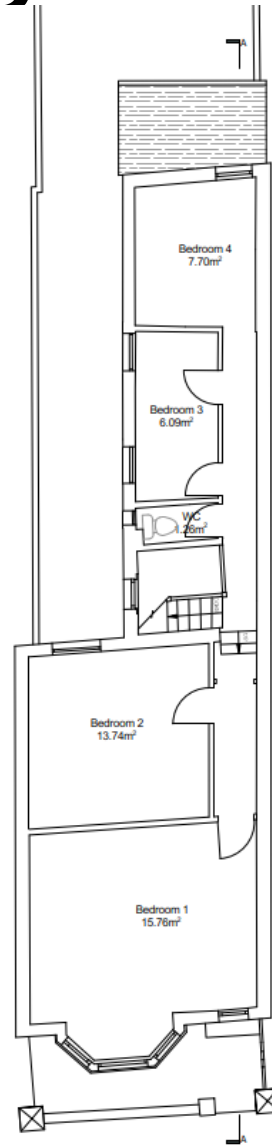

FIRST FLOOR PLAN
SCALE 1:50

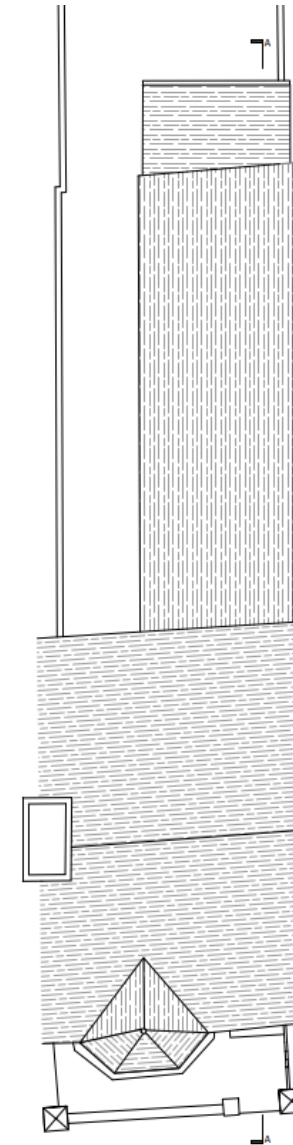

ROOF PLAN
SCALE 1:50

Approved Elevations – MC/25/1263

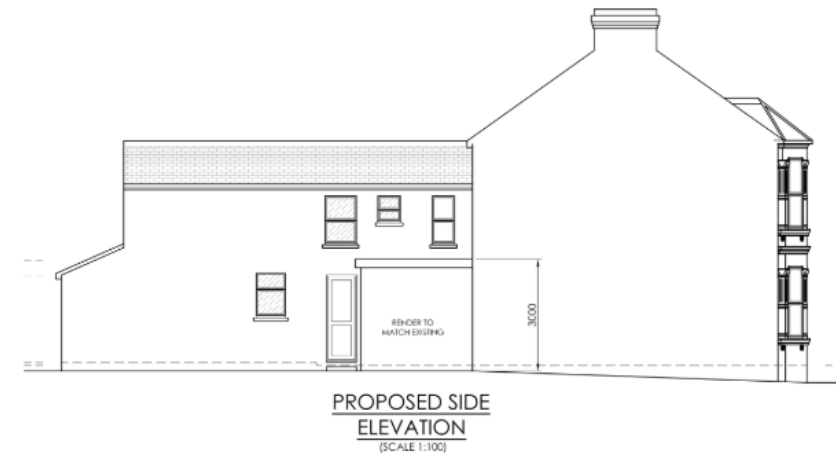
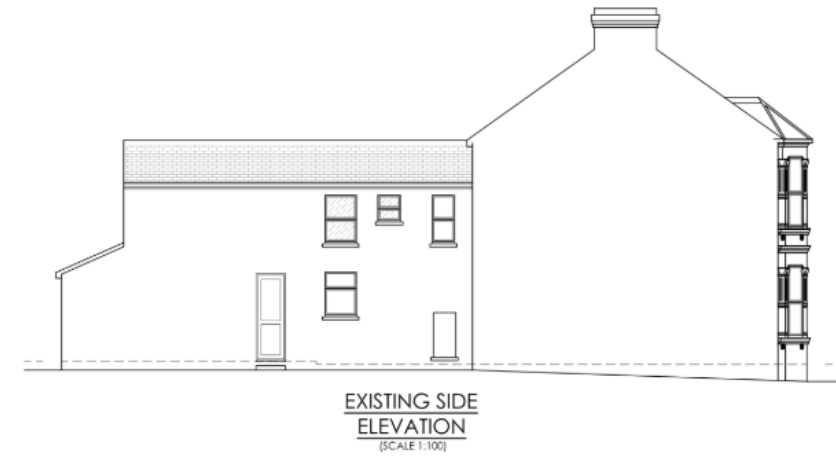
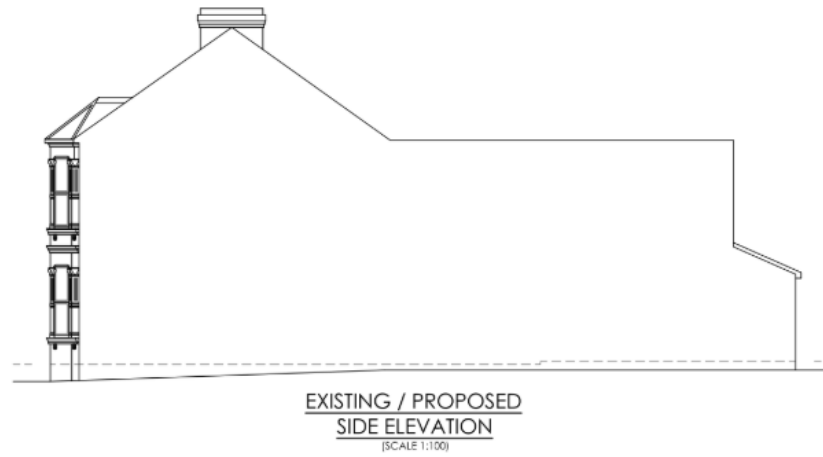
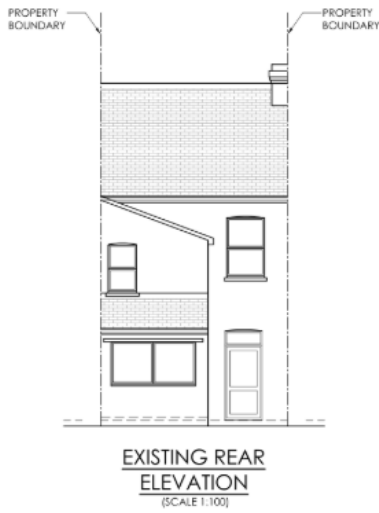

Approved Floor Plans – MC/25/1263

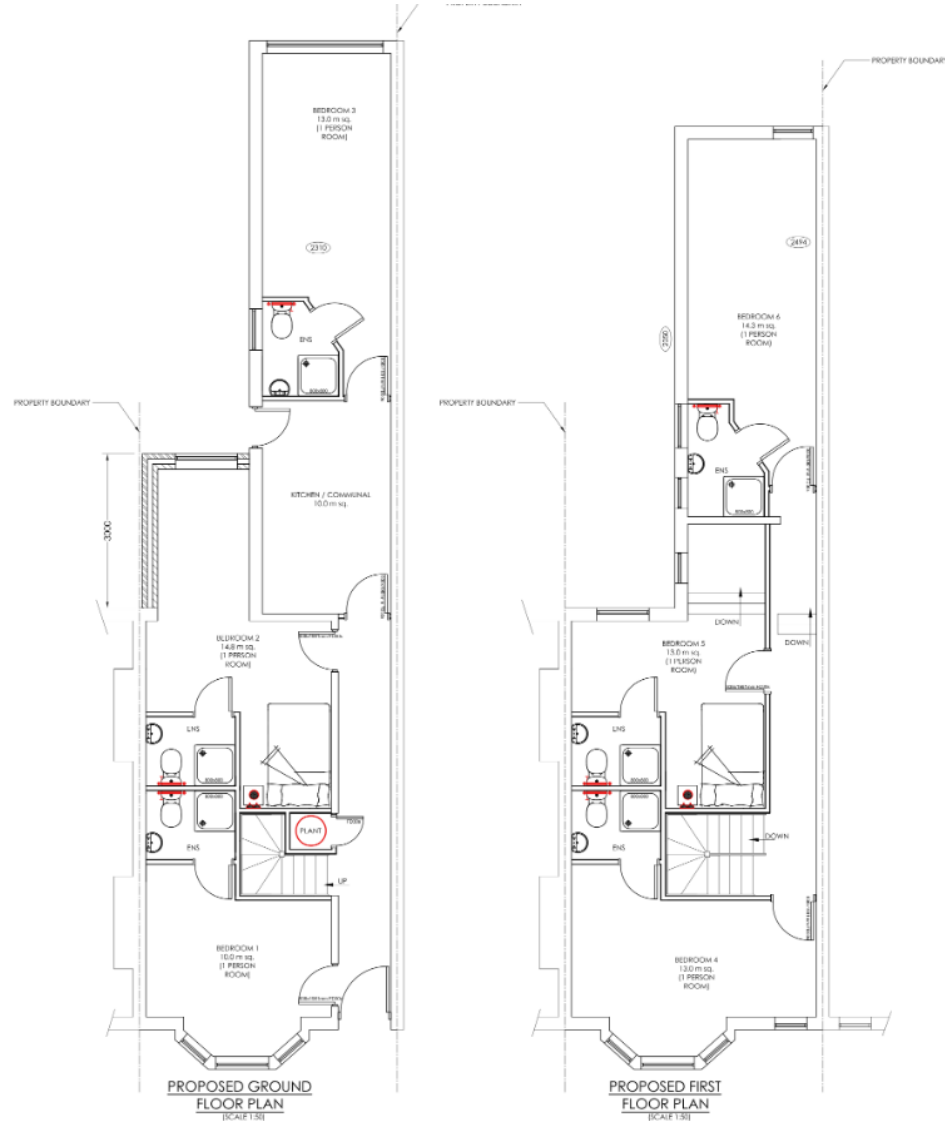

Proposed Elevations



FRONT ELEVATION
SCALE 1/50



REAR ELEVATION
SCALE 1/50

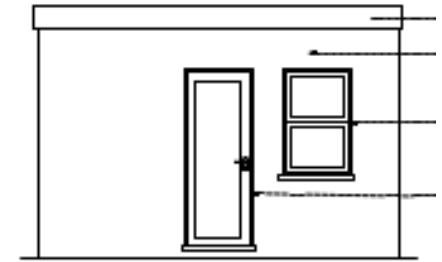

SHED FRONT ELEVATION
SCALE 1/50

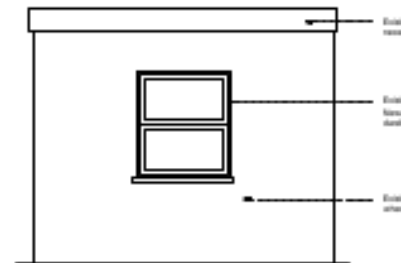

SHED SIDE ELEVATION
SCALE 1/50

Proposed section

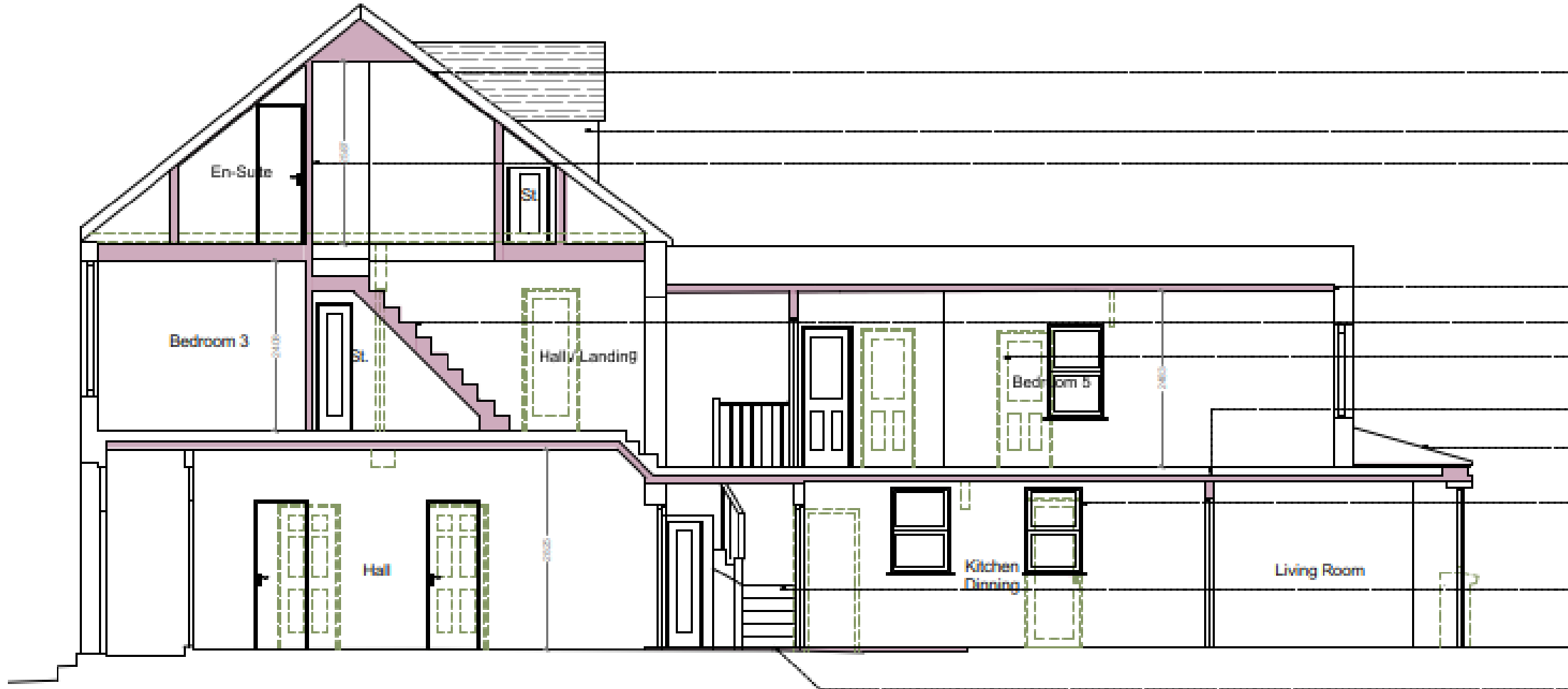

SECTION AA

SCALE 1:50

Proposed Floor Plans

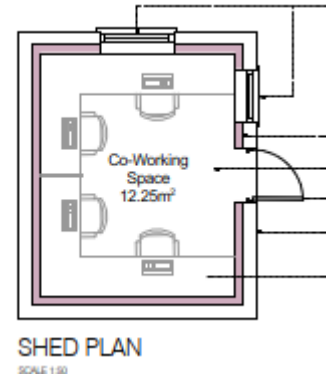
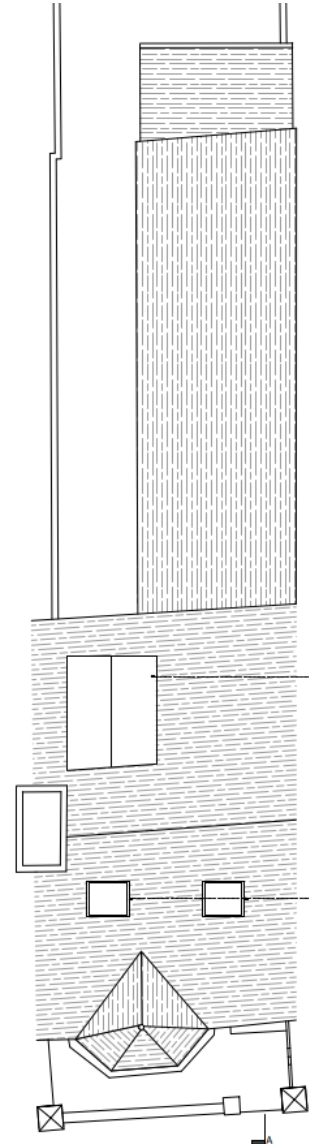
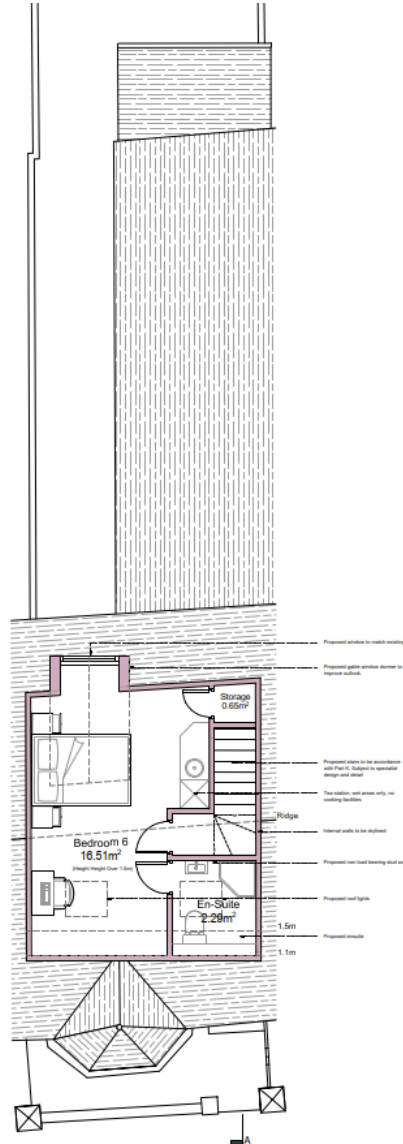
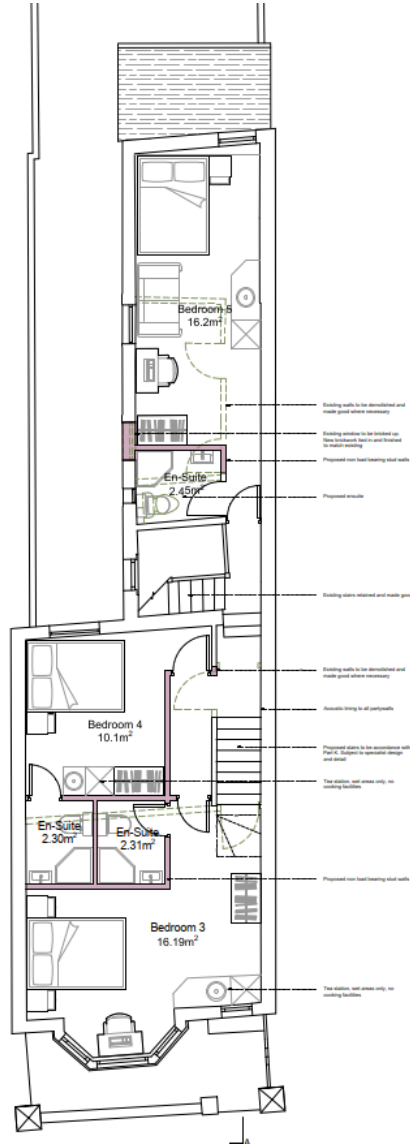
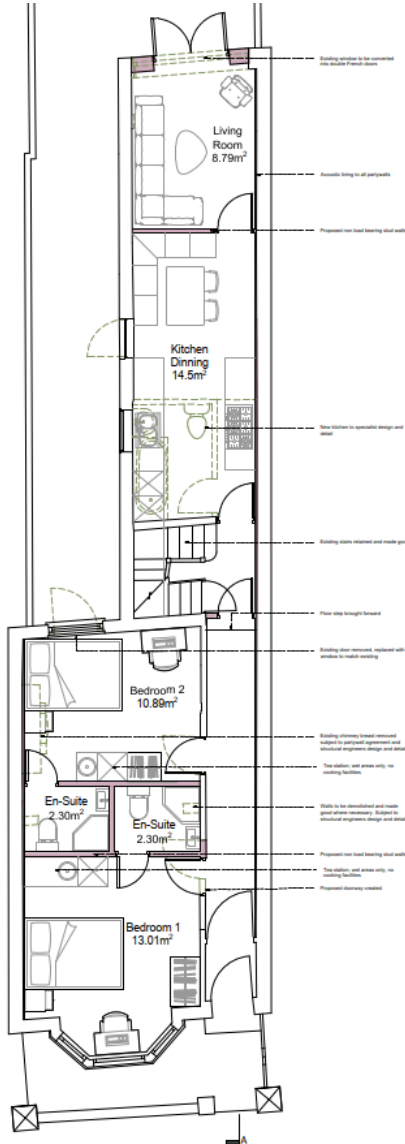

Proposed Site Plan and Cycle Storage



© Crown copyright 2025 Ordnance Survey 100053143

PROPOSED BLOCK PLAN

1:200 SCALE

1:200 SCALE

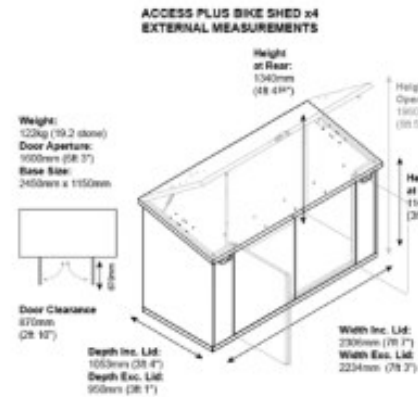

* Please note, this product needs approx 100mm clearance at the back (from a wall/fence) as the top sticks/swings out a little when the lid is lifted.

PROPOSED BIKE STORAGE UNIT



HMO Density

● - Application Property

● - HMO

○ - 500m Radius

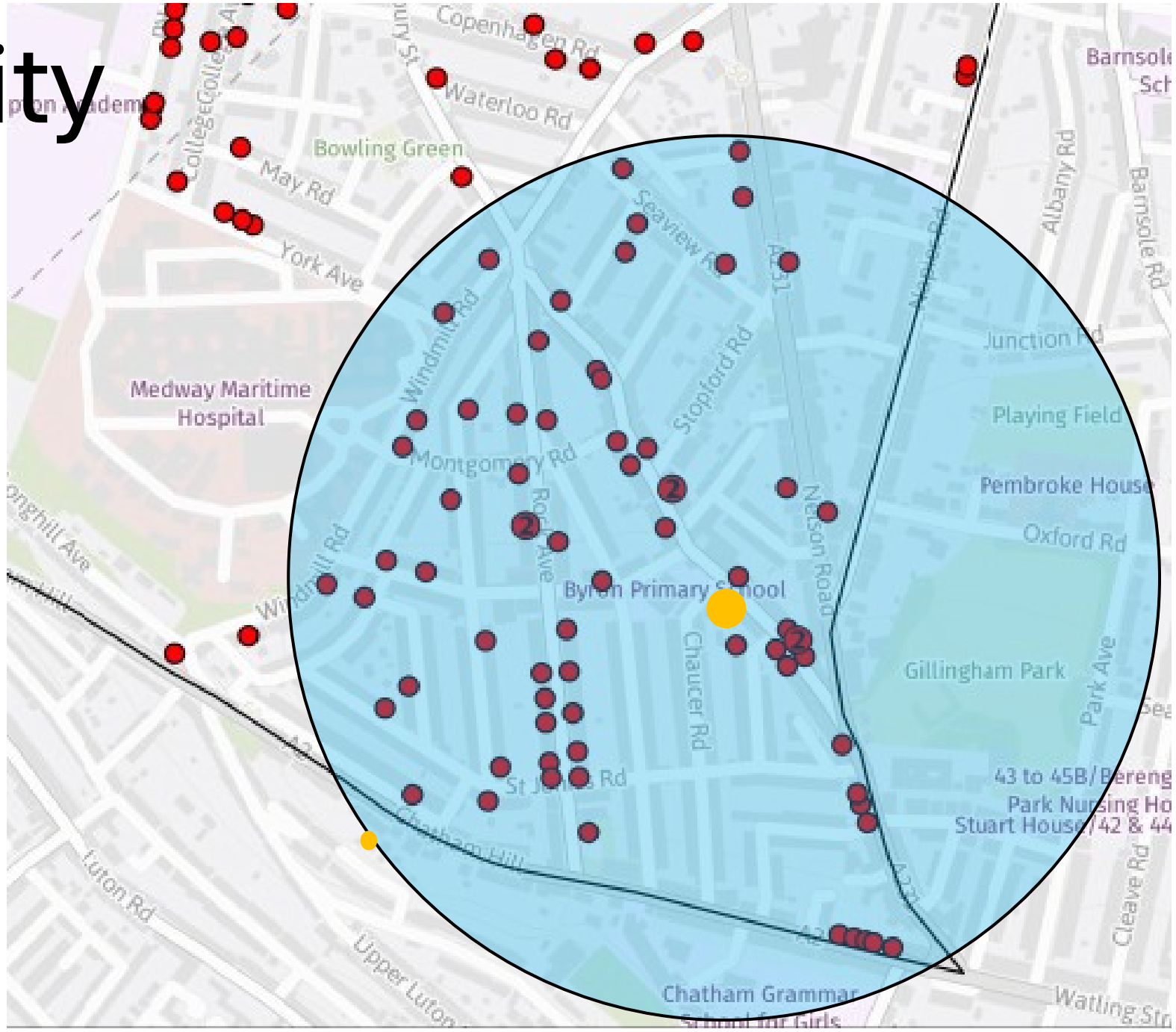

MC/26/0221

58 York Avenue, Gillingham, ME7 5JG

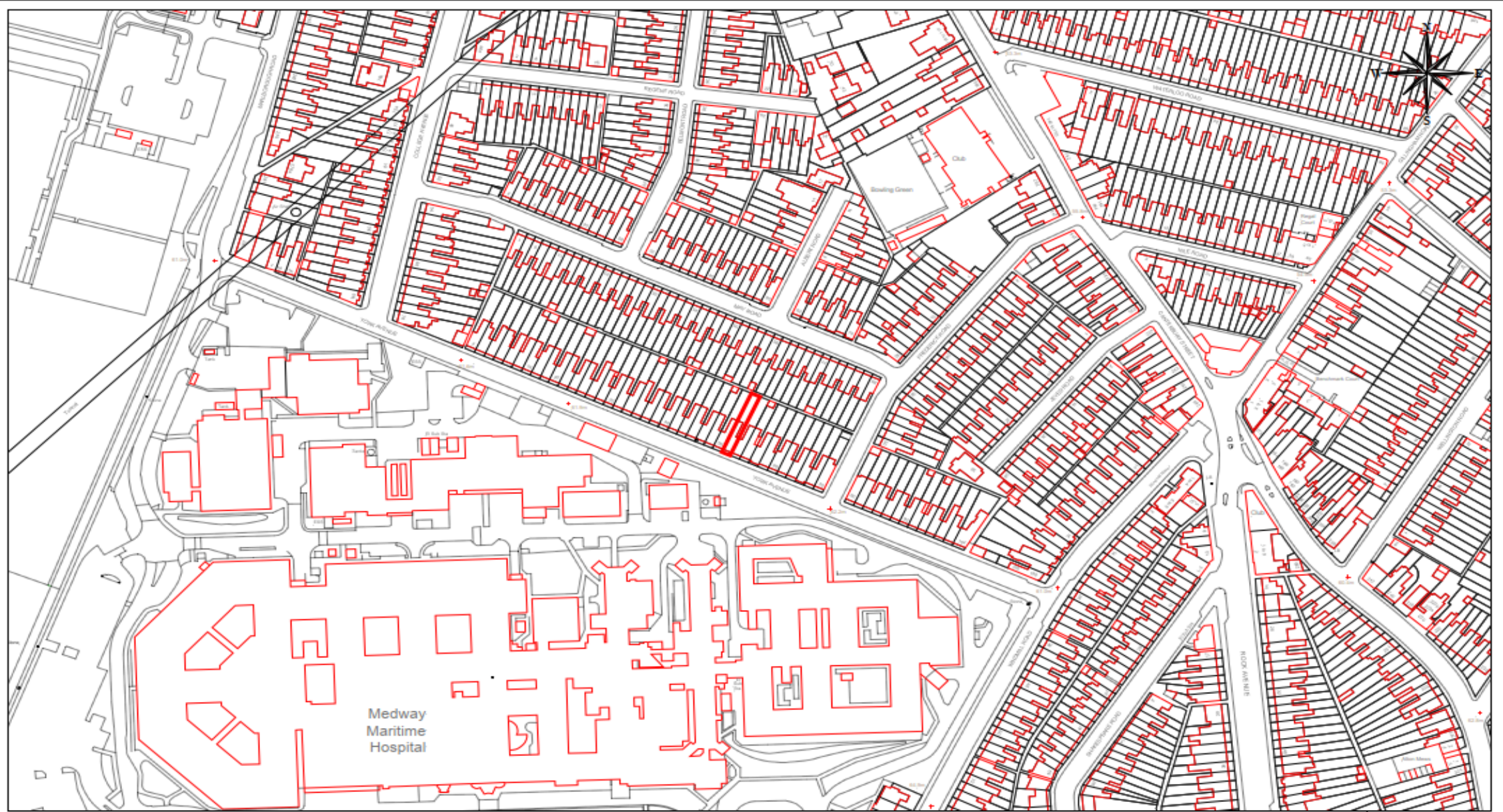

MC/26/0221 - 58 York Avenue, Gillingham, ME7 5JG



Site Location

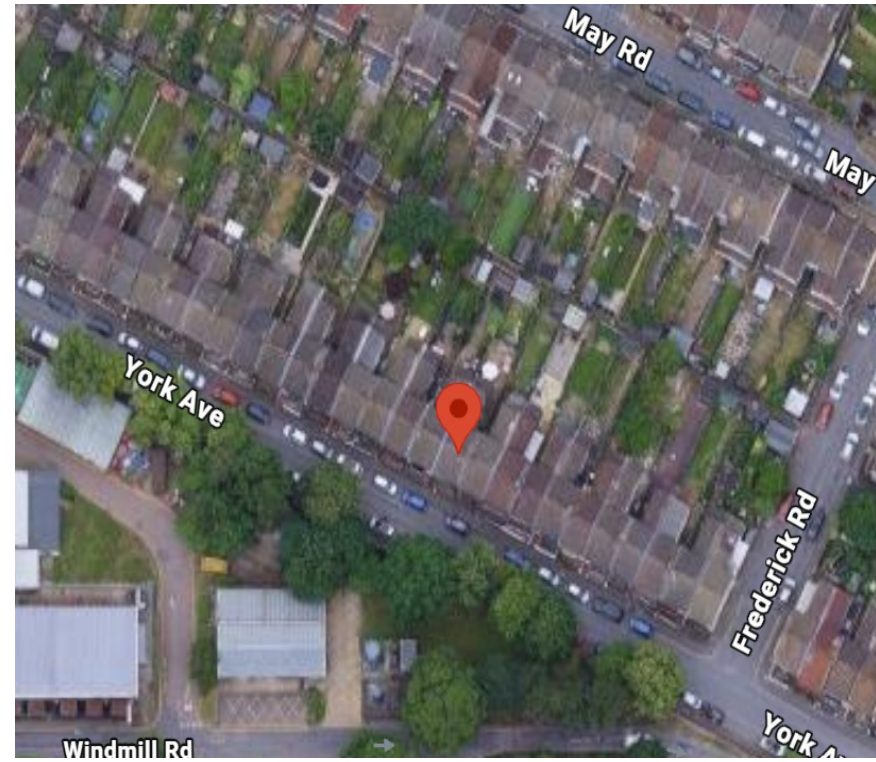
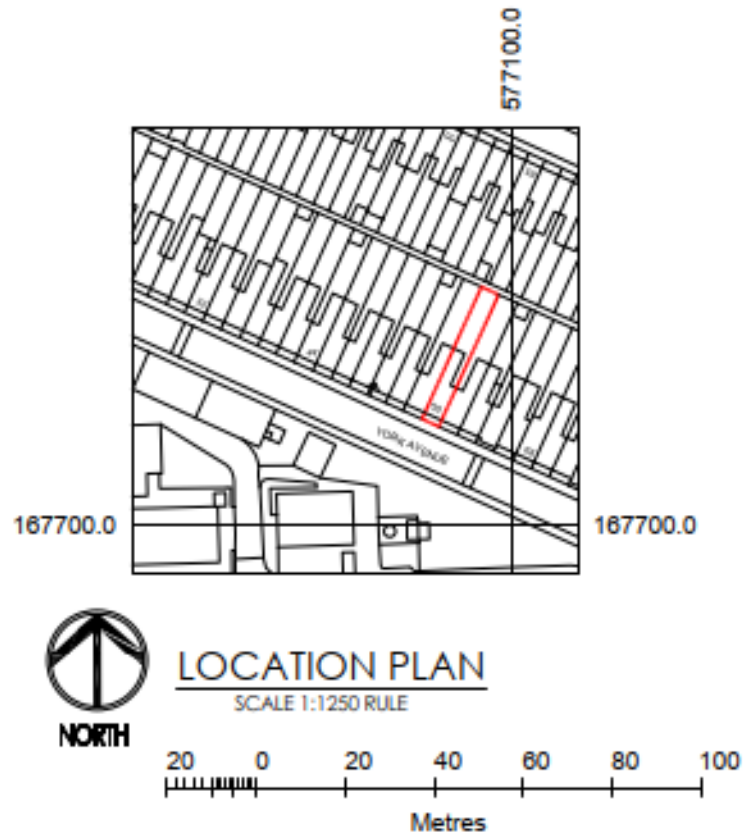

Existing Floor Plans

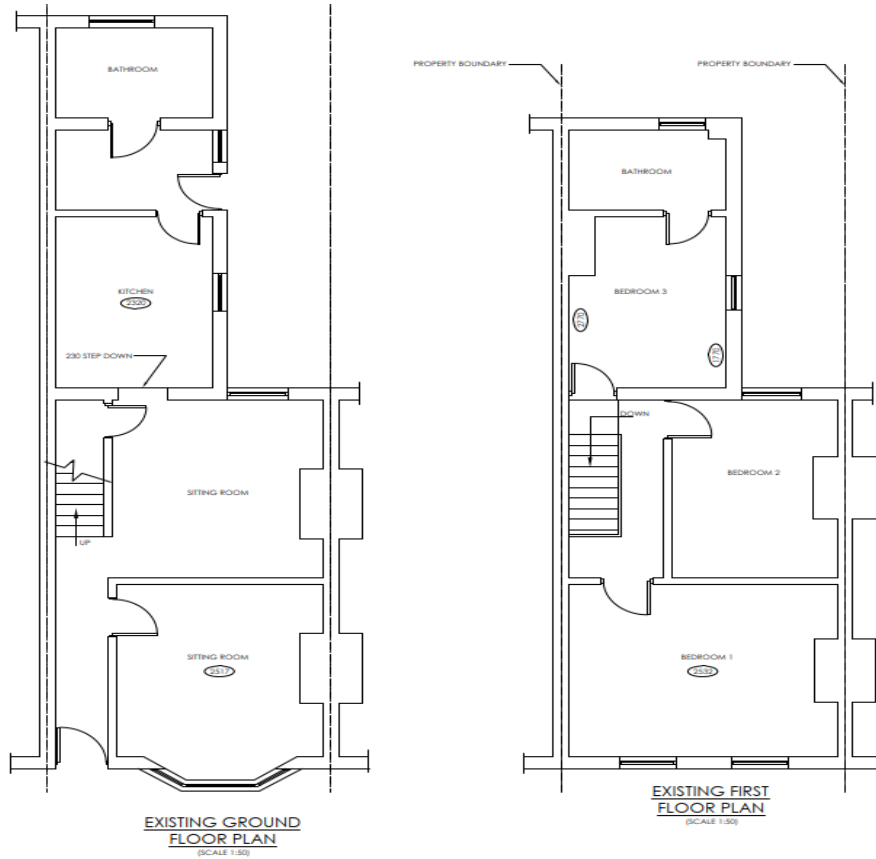

Ground Floor – two sitting rooms, Kitchen and bathroom

First Floor Plan - 3 bedrooms one with ensues

Second floor - 2 bedrooms with ensues
There is also a garden to the rear.

Existing Elevations



EXISTING FRONT
ELEVATION
(SCALE 1:100)

EXISTING REAR
ELEVATION
(SCALE 1:100)

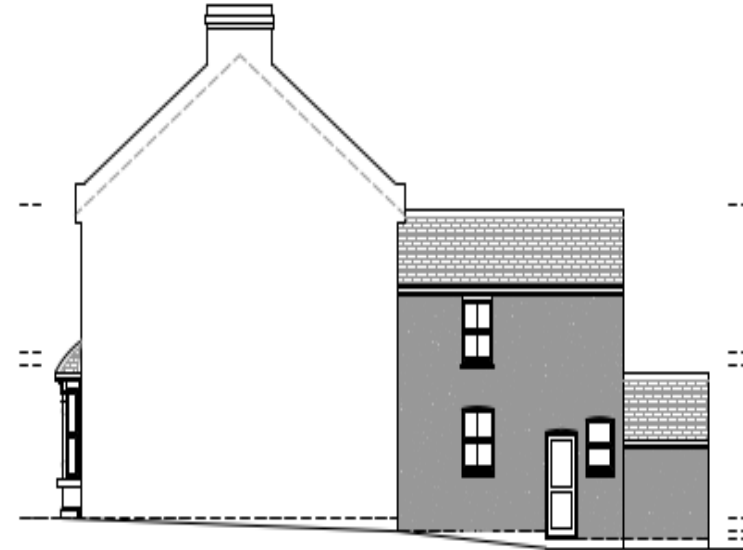

EXISTING SIDE
ELEVATION
(SCALE 1:100)

DORNIER CONSTRUCTED IN
ACCORDANCE WITH PLANNING
APPLICATION REFERENCE I.I.C/25/1937

Proposed Floor Plans

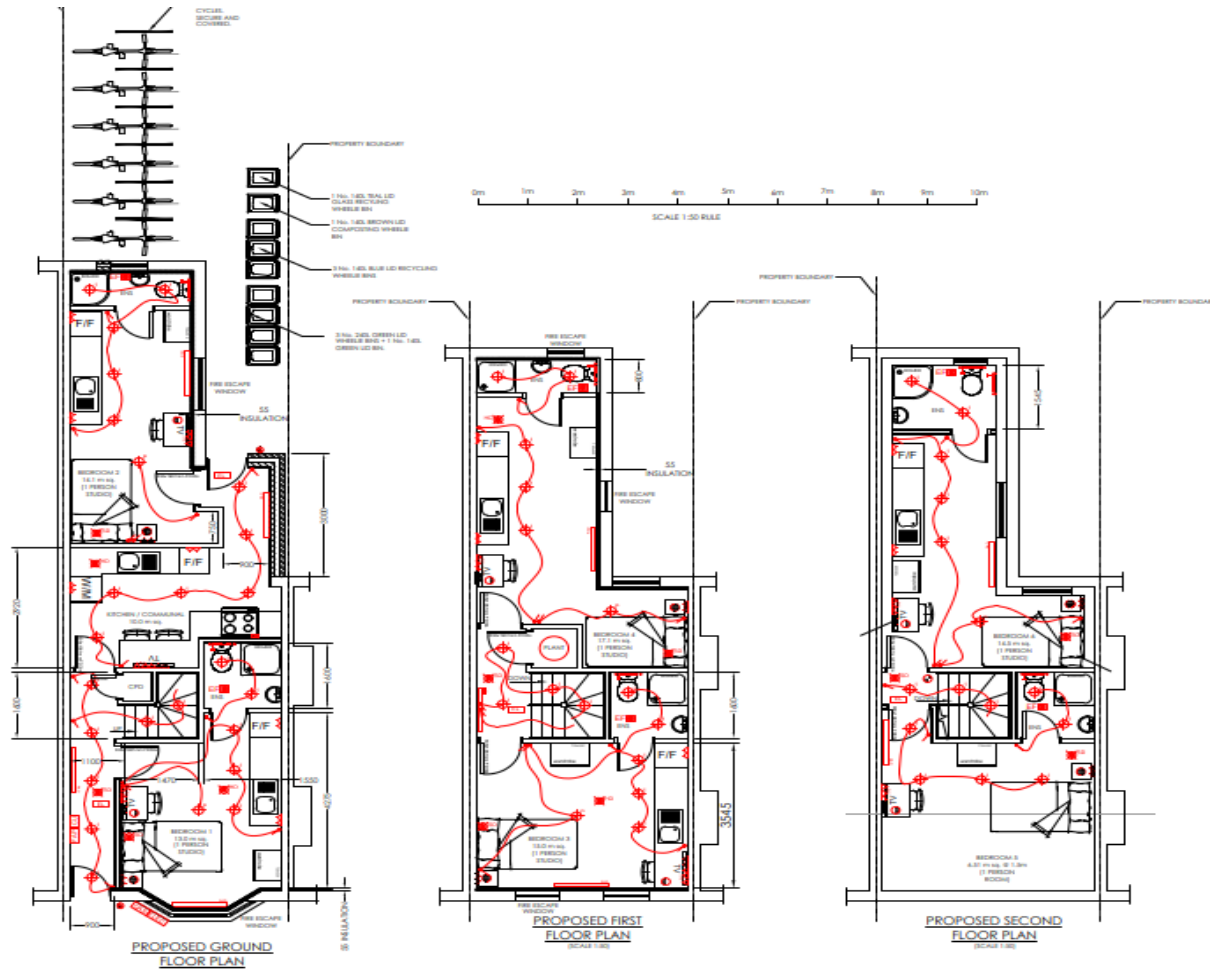

Ground Floor – Kitchen dining area and 2 bedrooms with ensues

First Floor Plan - 2 bedrooms with ensues

Second floor - 2 bedrooms with ensues
There is also a garden to the rear.

Proposed Elevations



**PROPOSED FRONT
ELEVATION**
(SCALE 1:100)

**PROPOSED REAR
ELEVATION**
(SCALE 1:100)

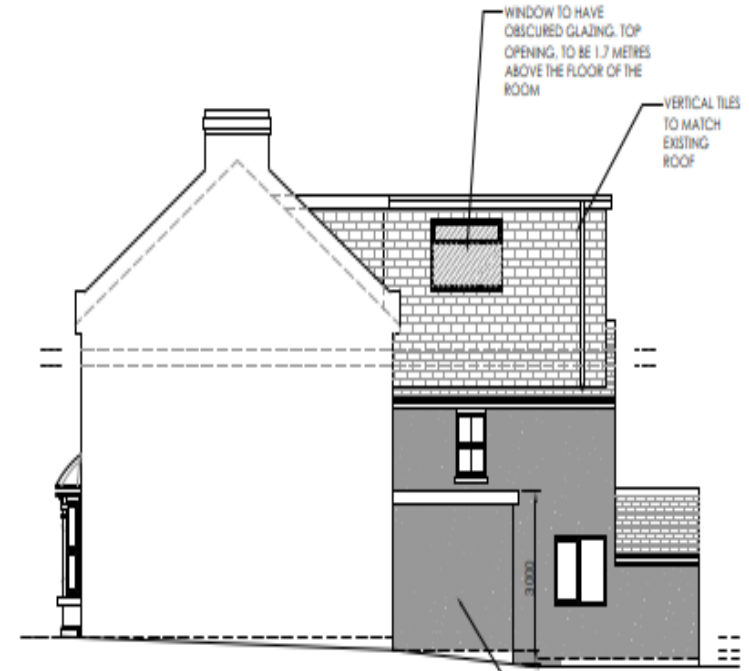

**PROPOSED SIDE
ELEVATION**
(SCALE 1:100)

HMO Density

● - Application Property

● - HMO

○ - 500m Radius

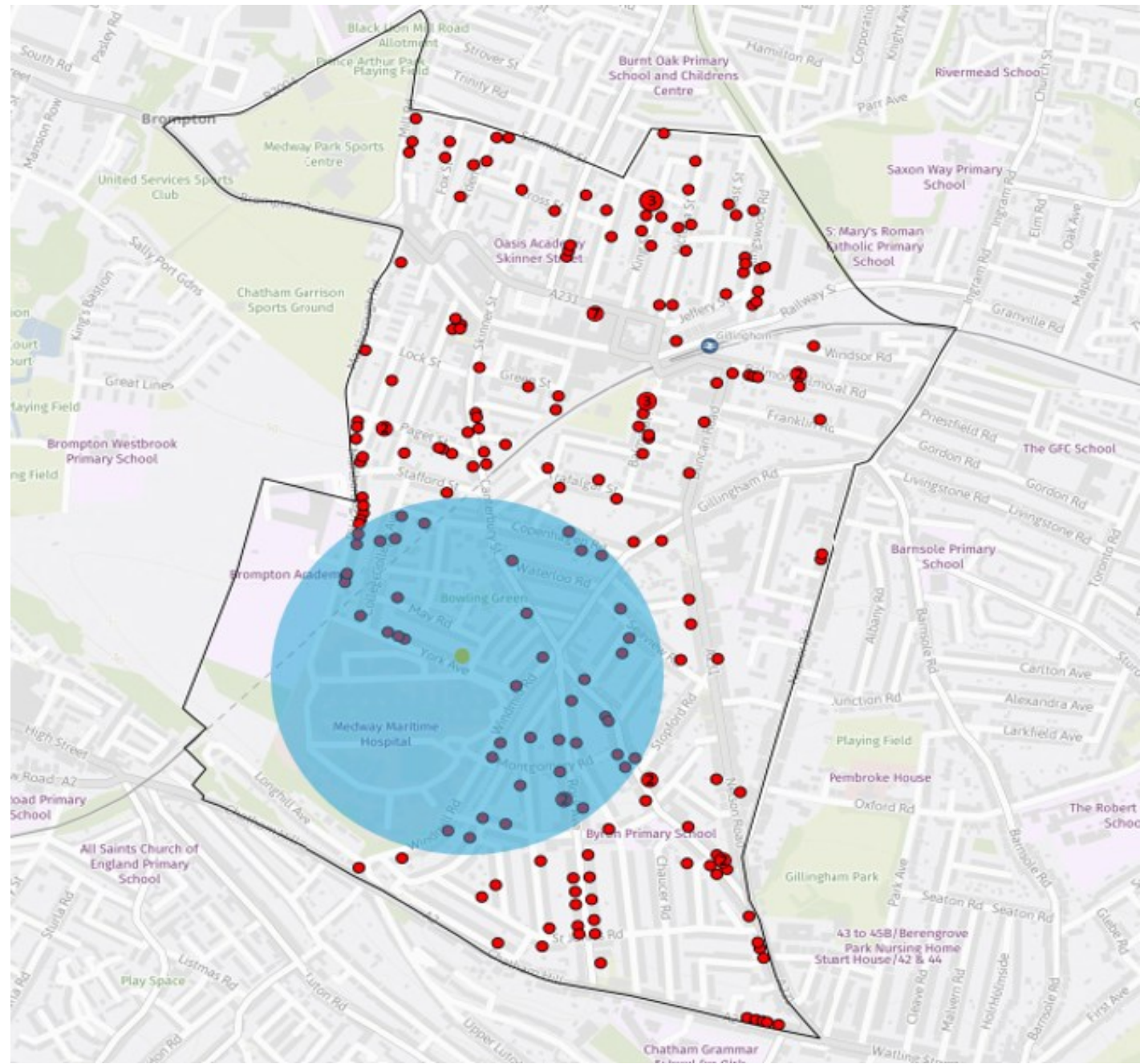

MC/26/0606

98 Grove Road, Strood, ME2 4BY

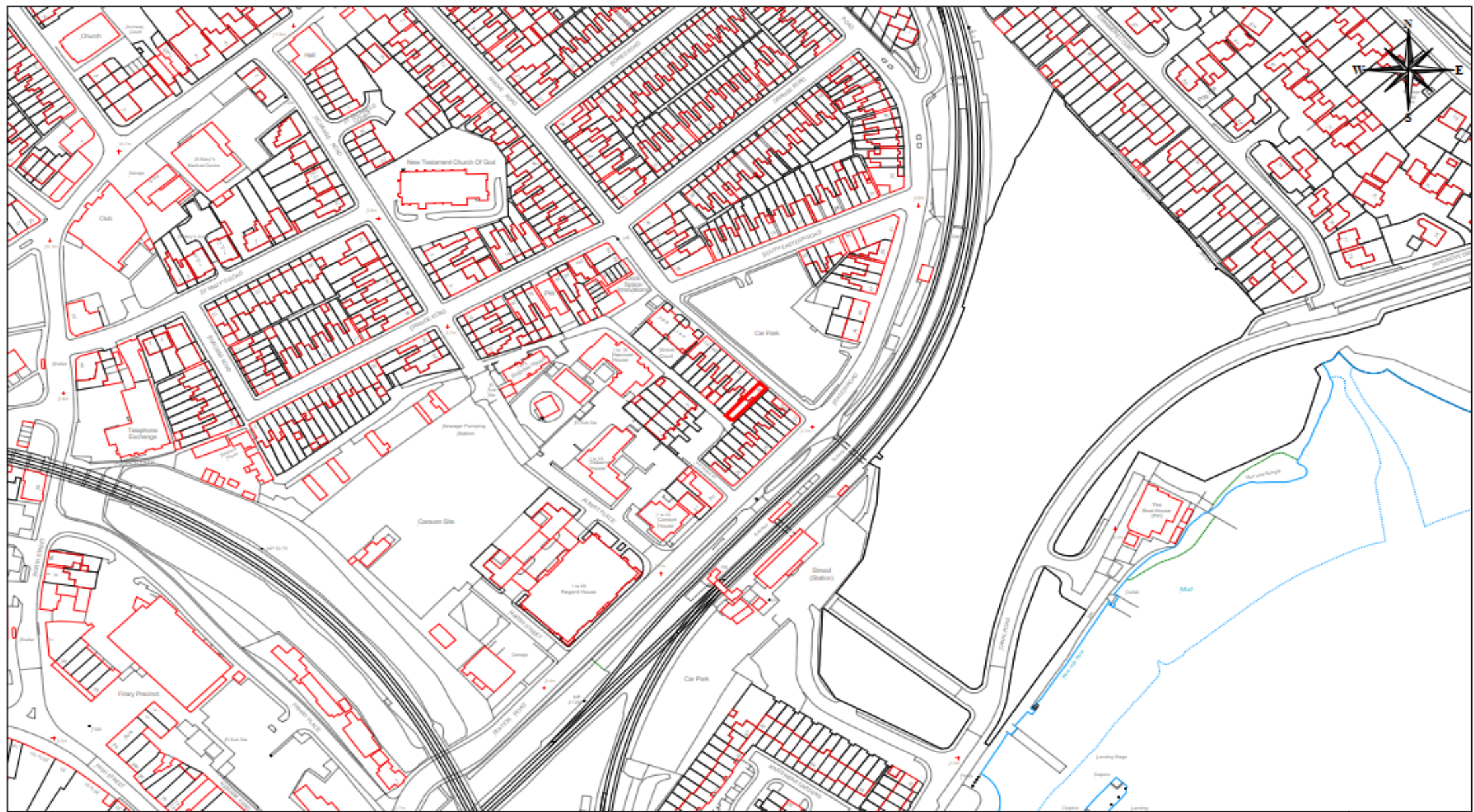

MC/26/0606 - 98 Grove Road, Strood, Rochester, ME2 4BY

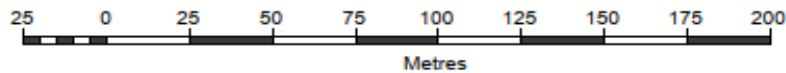

Site Location



Site Photos



Existing and Proposed Block Plans

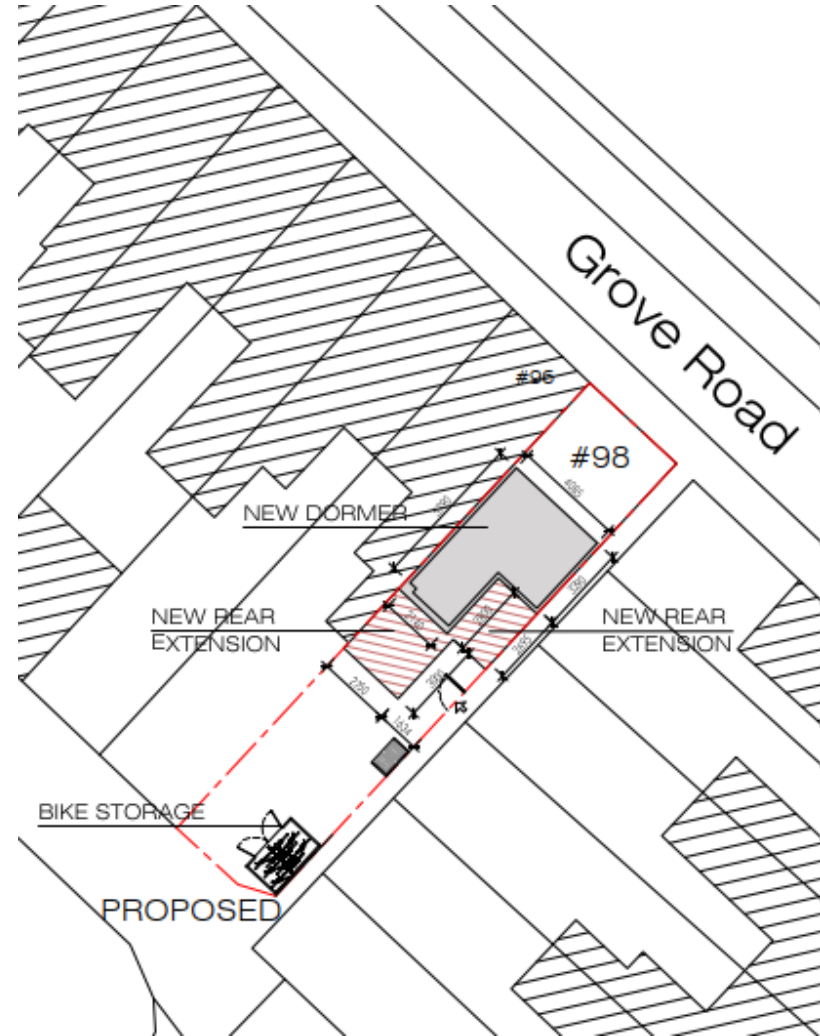
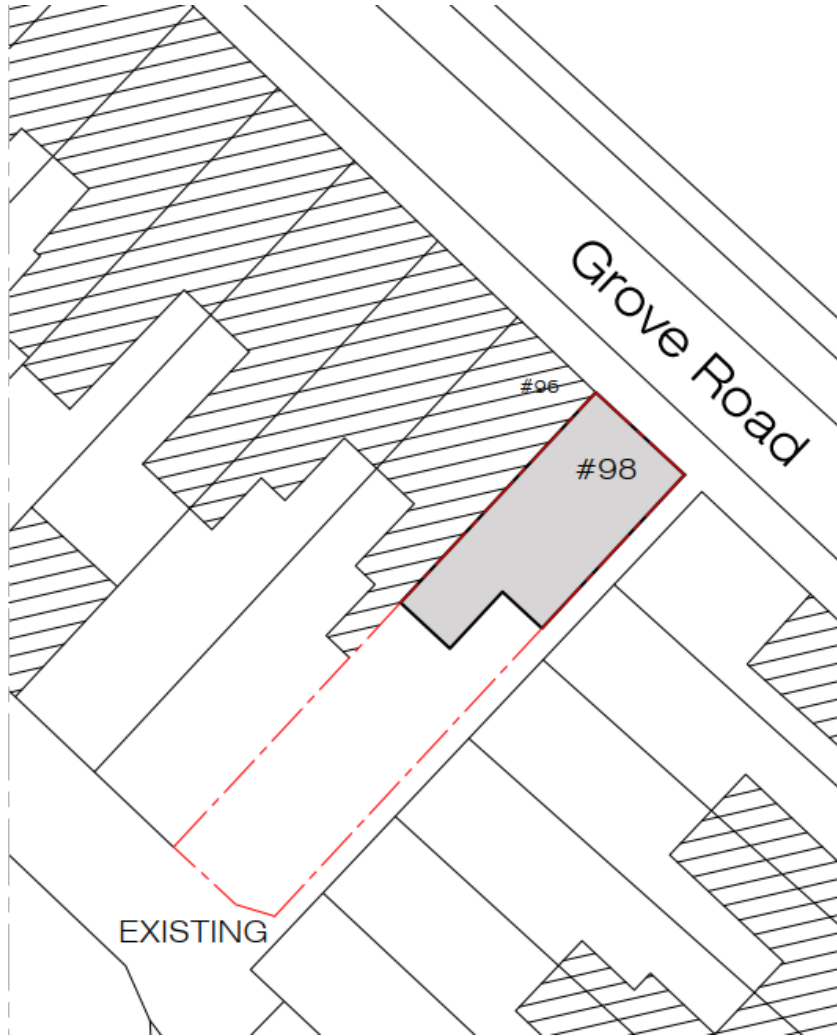

Existing Plans and Elevations

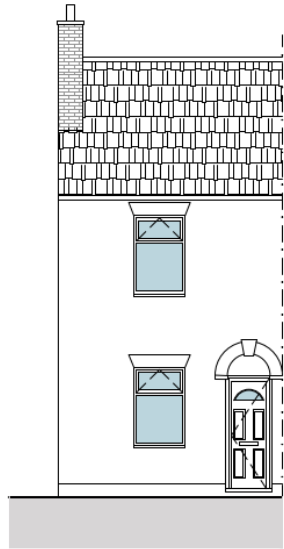

EXISTING FRONT ELEVATION

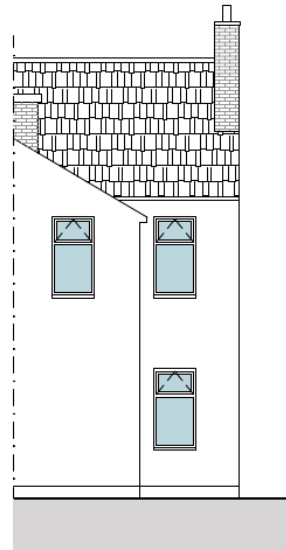

EXISTING REAR ELEVATION

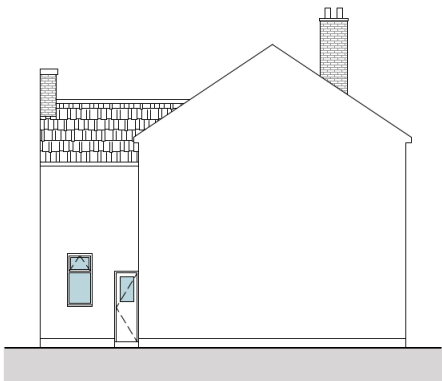

EXISTING LEFT SIDE ELEVATION

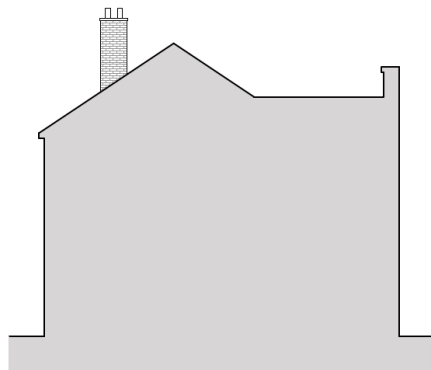

EXISTING RIGHT SIDE ELEVATION

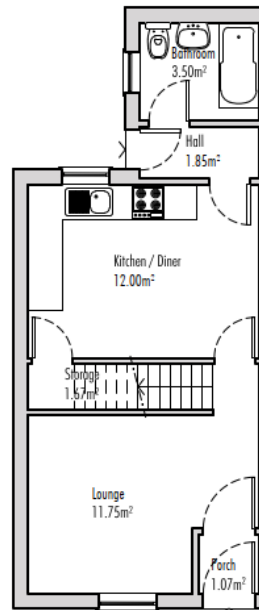

EXISTING GROUND FLOOR

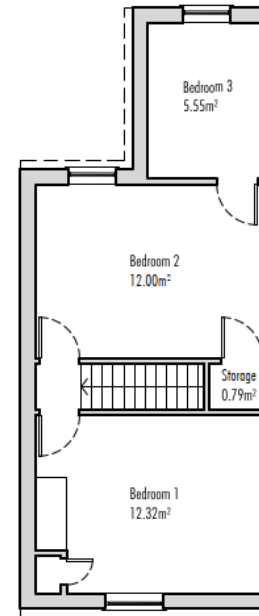

EXISTING FIRST FLOOR

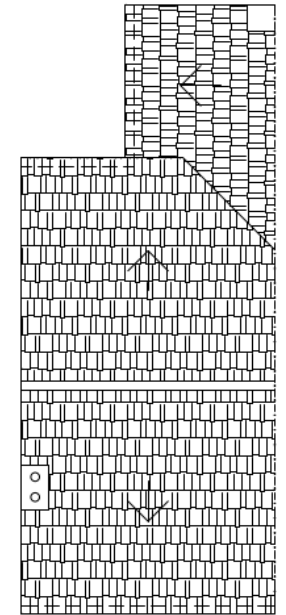

EXISTING ROOF

Plans and Elevations of Planning Application (MC/25/2499)

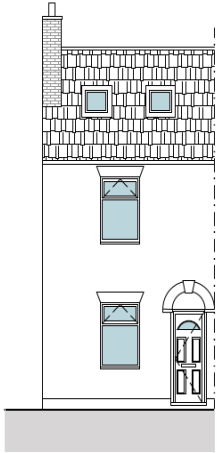

PROPOSED FRONT ELEVATION

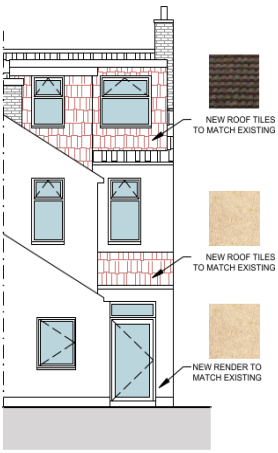

PROPOSED REAR ELEVATION

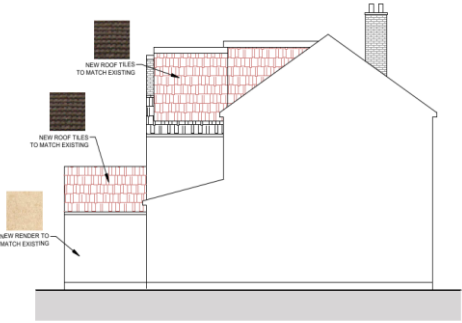

PROPOSED LEFT SIDE ELEVATION

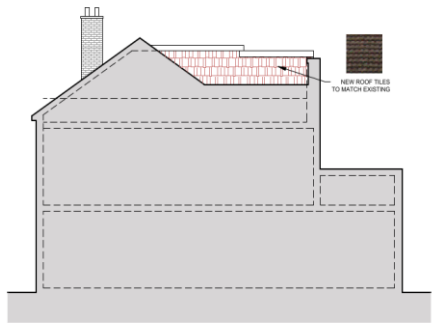

PROPOSED RIGHT SIDE ELEVATION

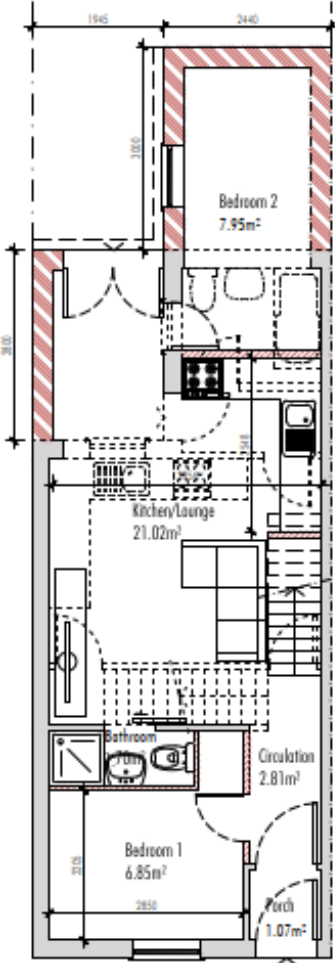

PROPOSED GROUND FLOOR

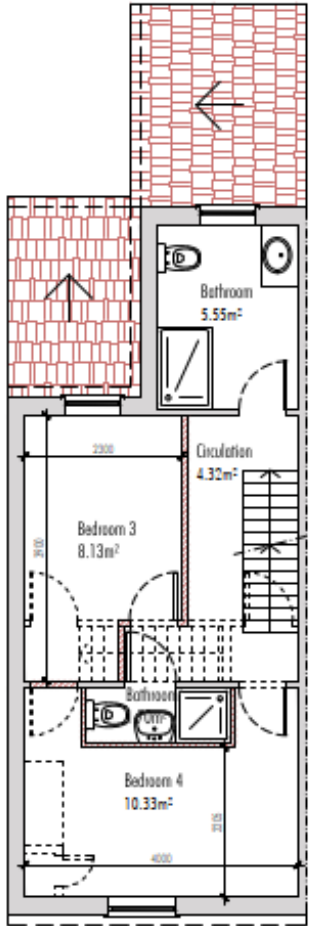

PROPOSED FIRST FLOOR

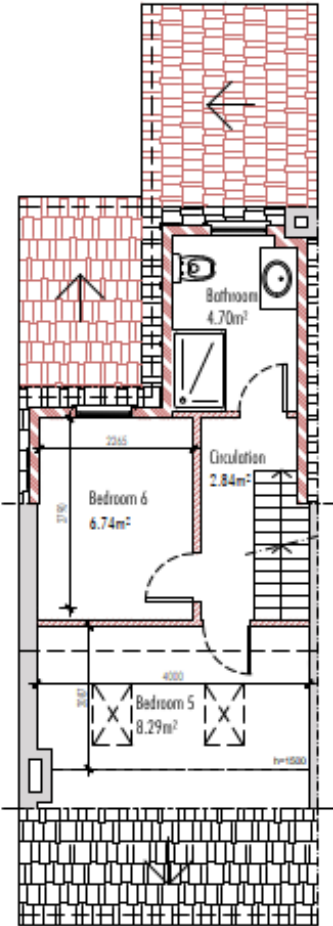

PROPOSED FIRST FLOOR

Proposed Plans and Elevations

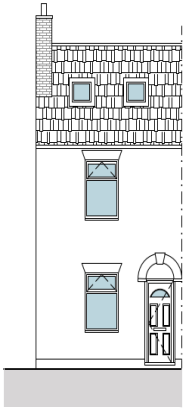

PROPOSED FRONT ELEVATION

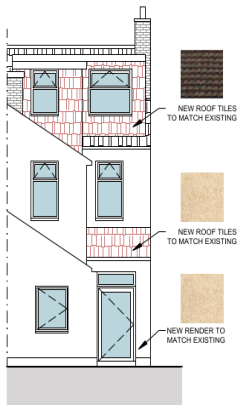

PROPOSED REAR ELEVATION

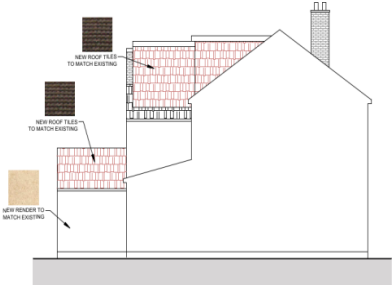

PROPOSED LEFT SIDE ELEVATION

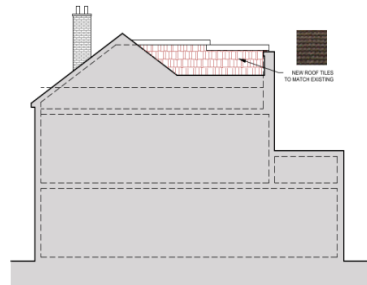

PROPOSED RIGHT SIDE ELEVATION

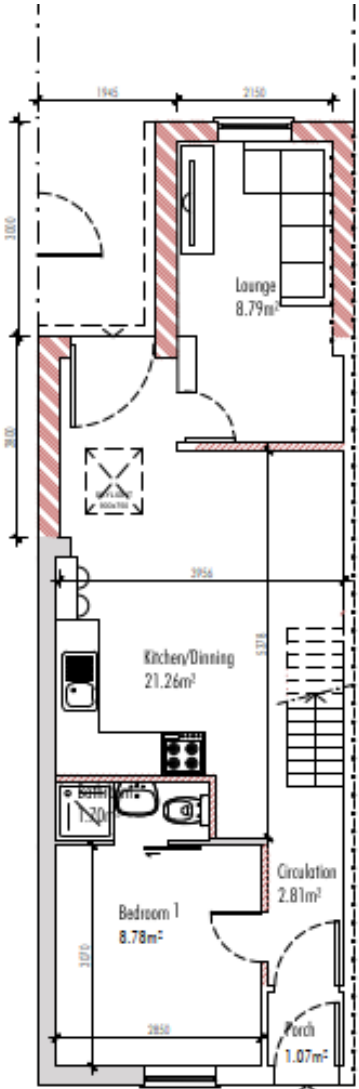

PROPOSED GROUND FLOOR

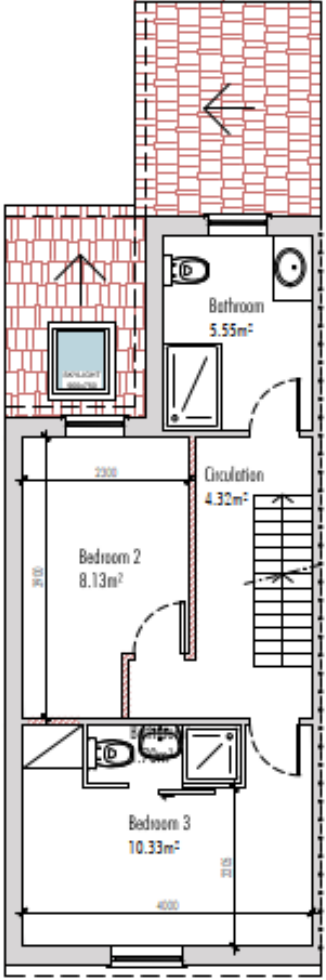

PROPOSED FIRST FLOOR

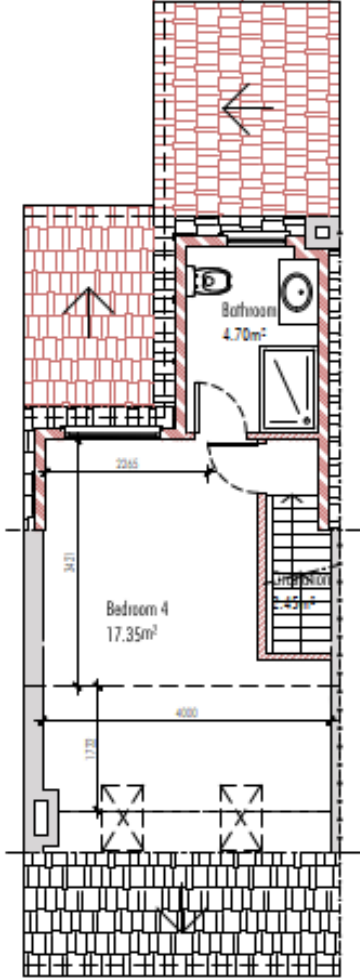

PROPOSED FIRST FLOOR

Proposed Cycle and Refuse Storage

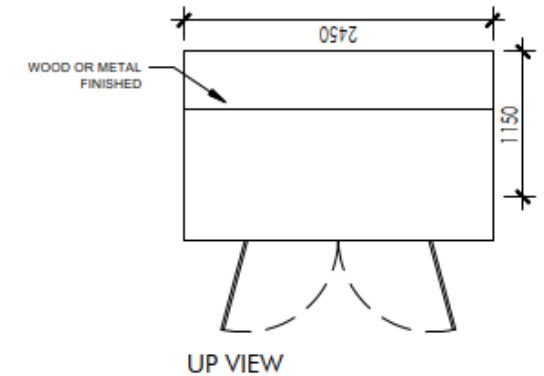
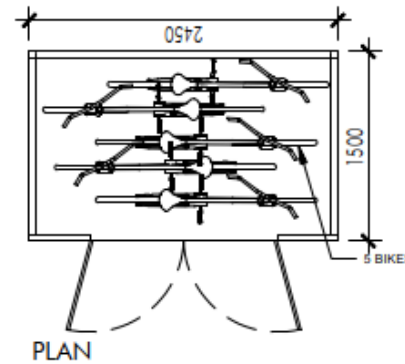
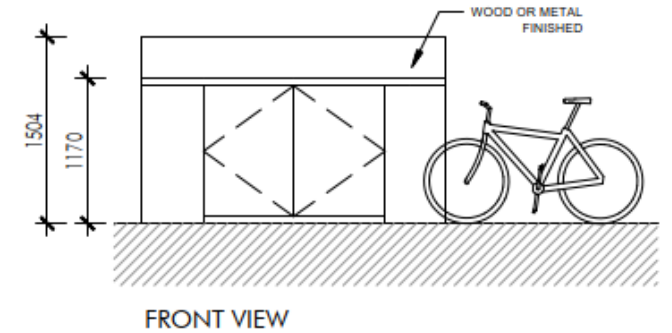
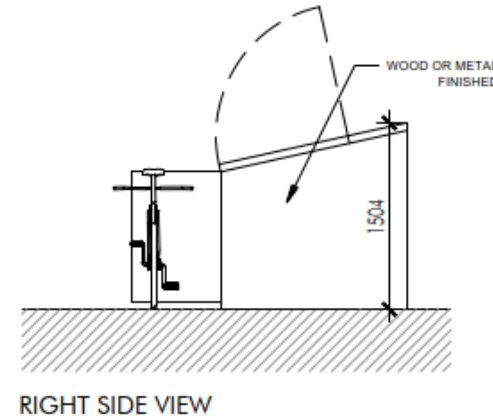
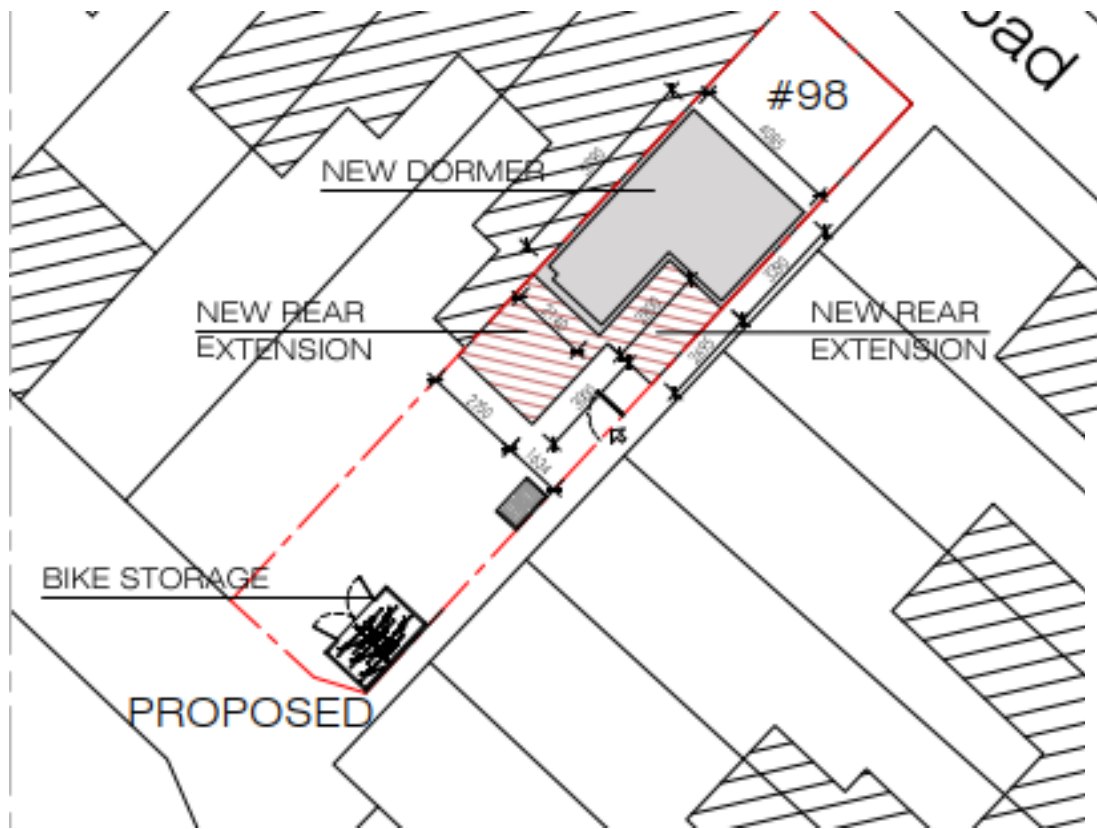

HMO Density

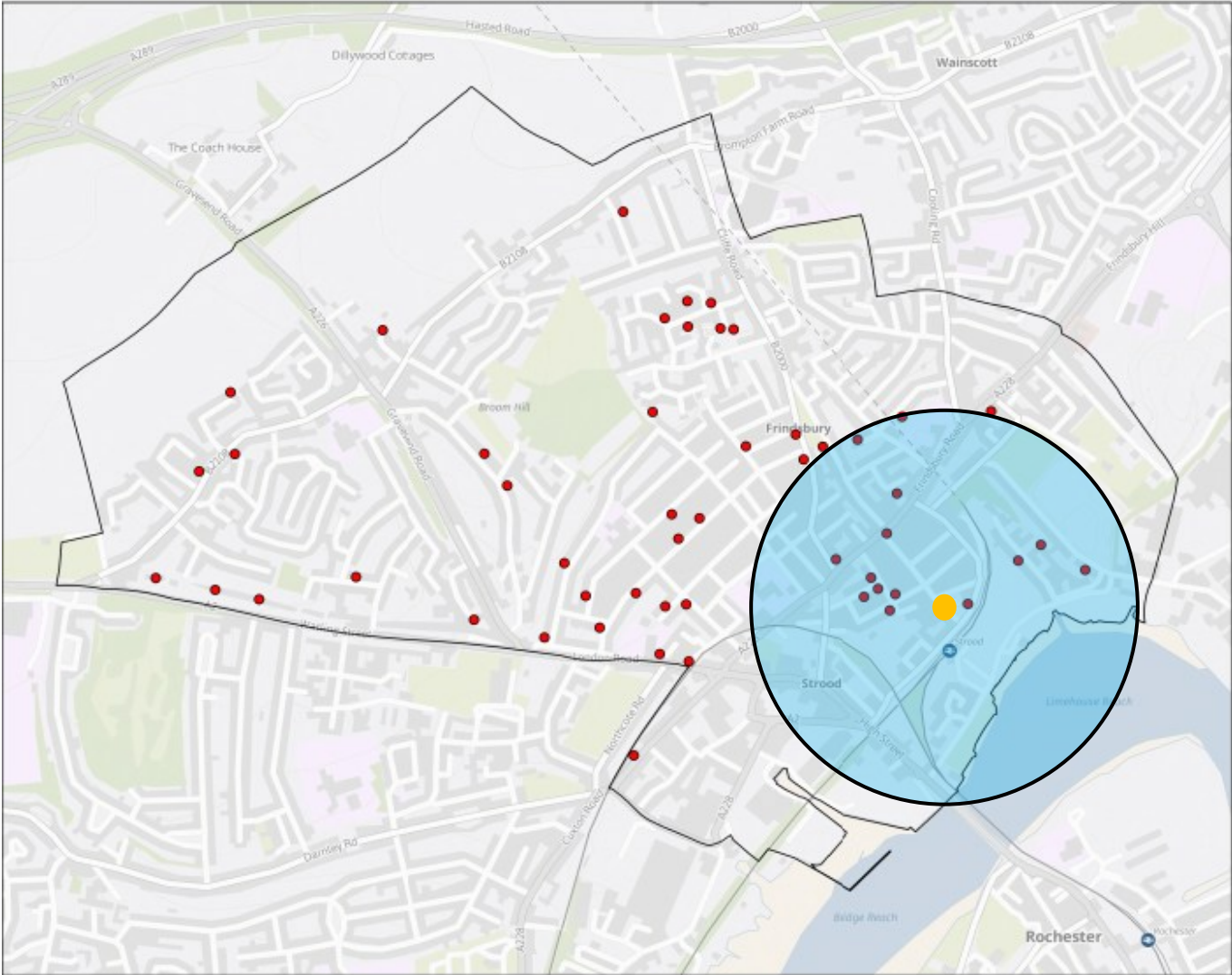

Key



Application property



HMO

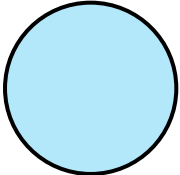

500m Radius

MC/26/0385

98 Howard Avenue, Rochester, ME 1 2AN

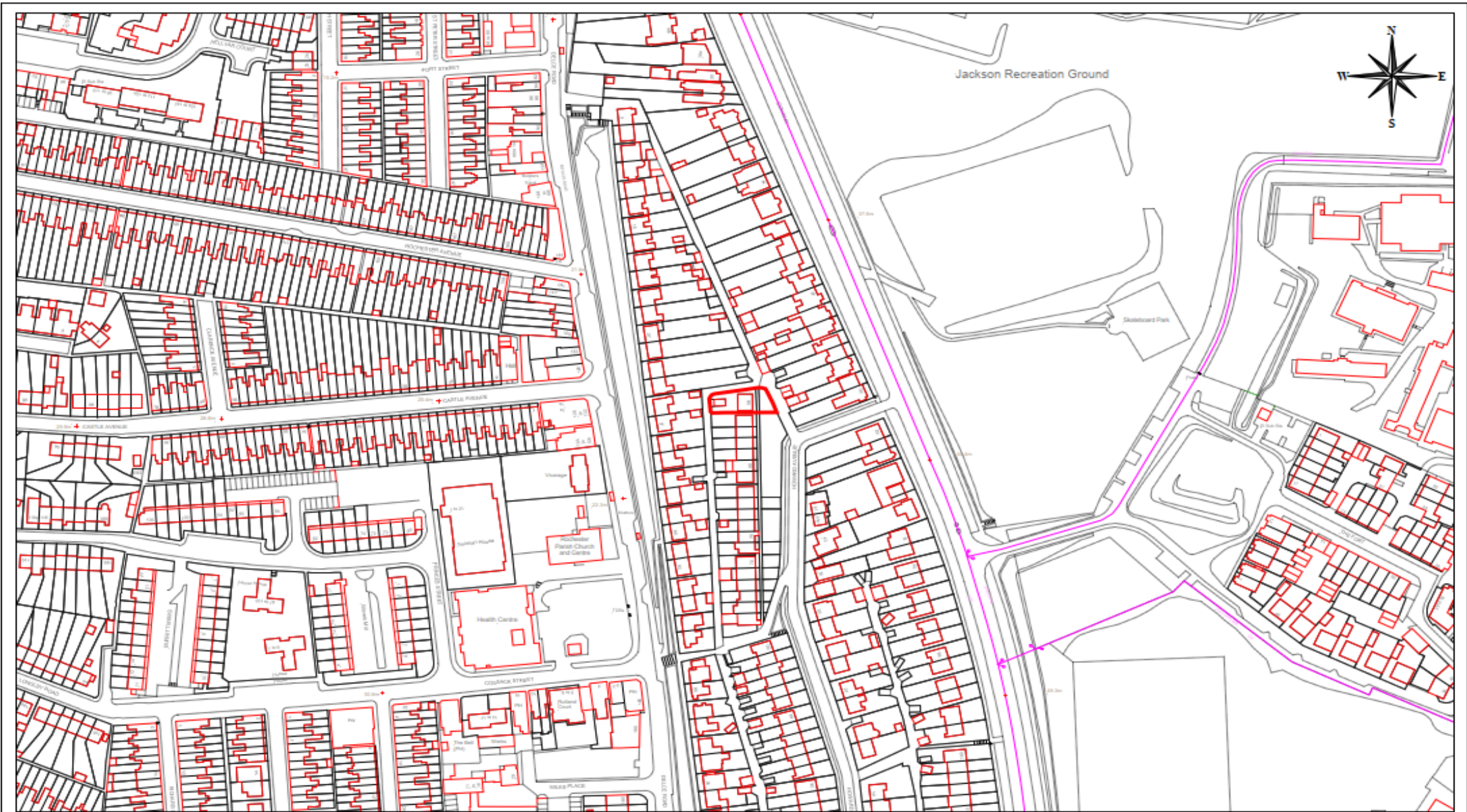

MC/26/0385 - 98 Howard Avenue, Rochester, ME1 2AN

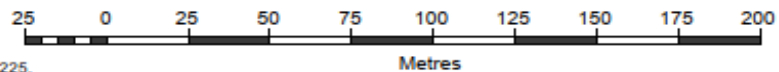

Site Overview





Site Photographs:
Front





Site Photographs: Side & Rear



Existing Floor & Roof Plans

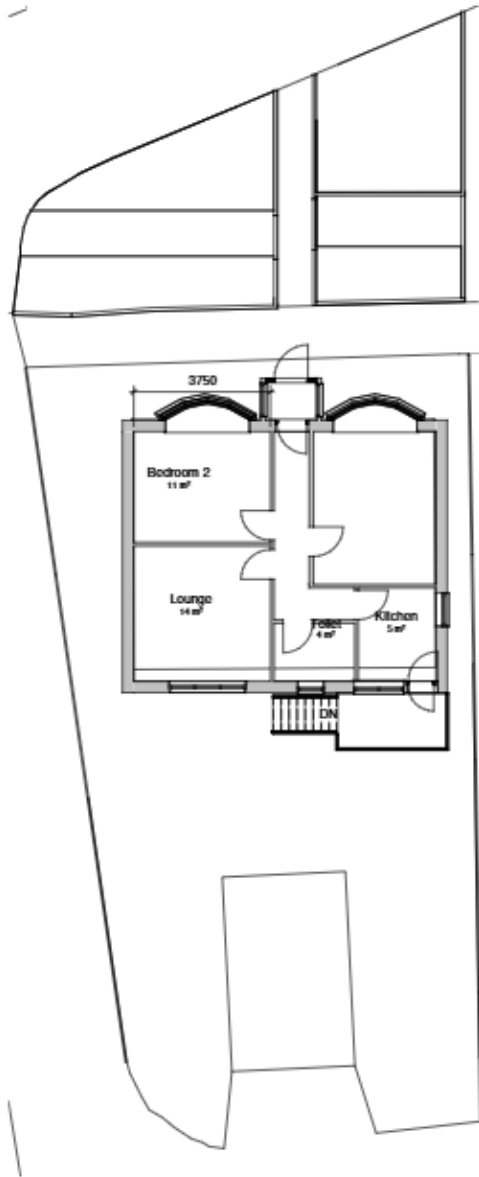

Ground Floor GIA
1 : 100

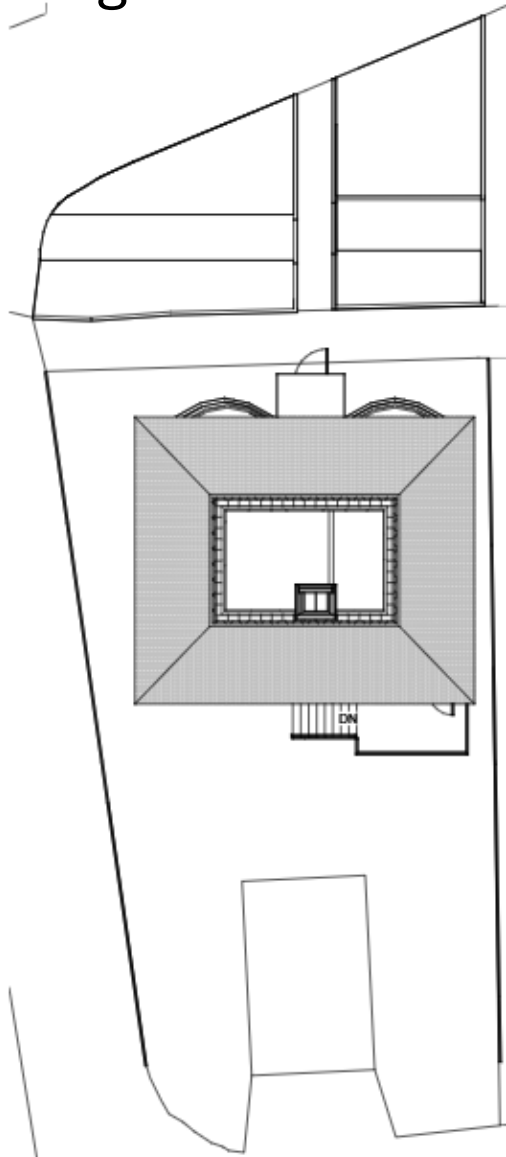

Existing First Floor
1 : 100

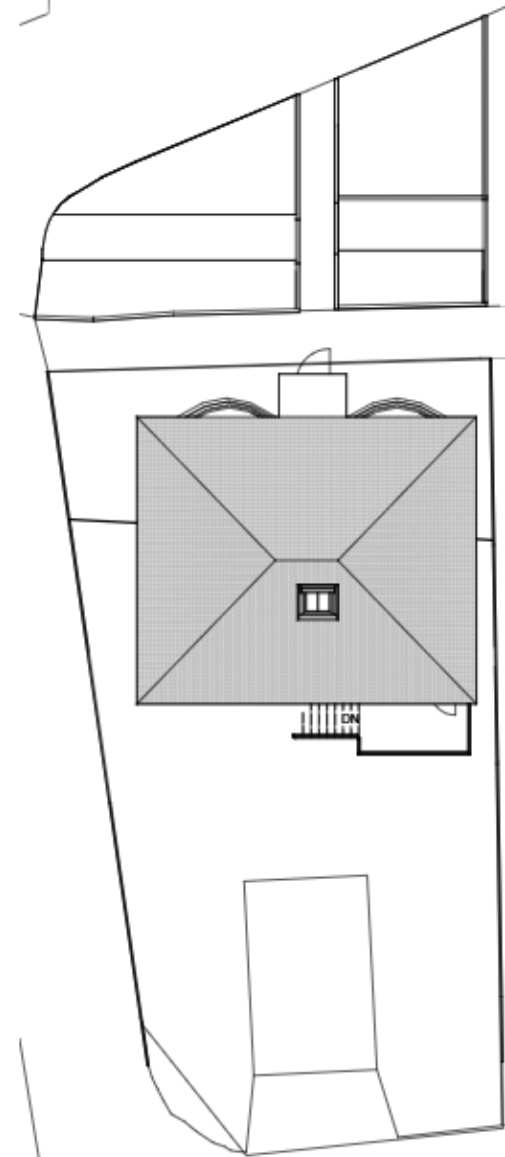

Existing Roof Plan
1 : 100

MC/25/2534 – Previously Approved Floor & Roof Plans

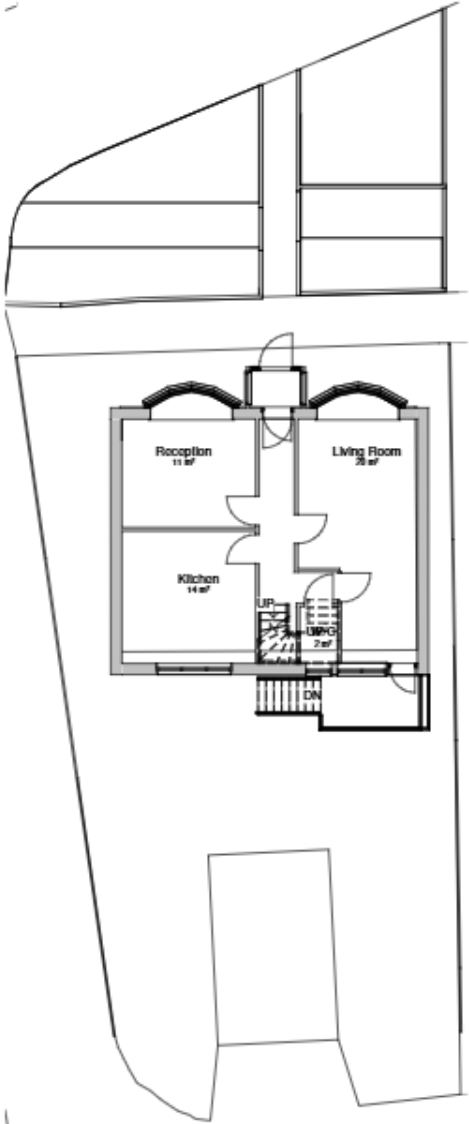

Proposed Ground Floor
1 : 100

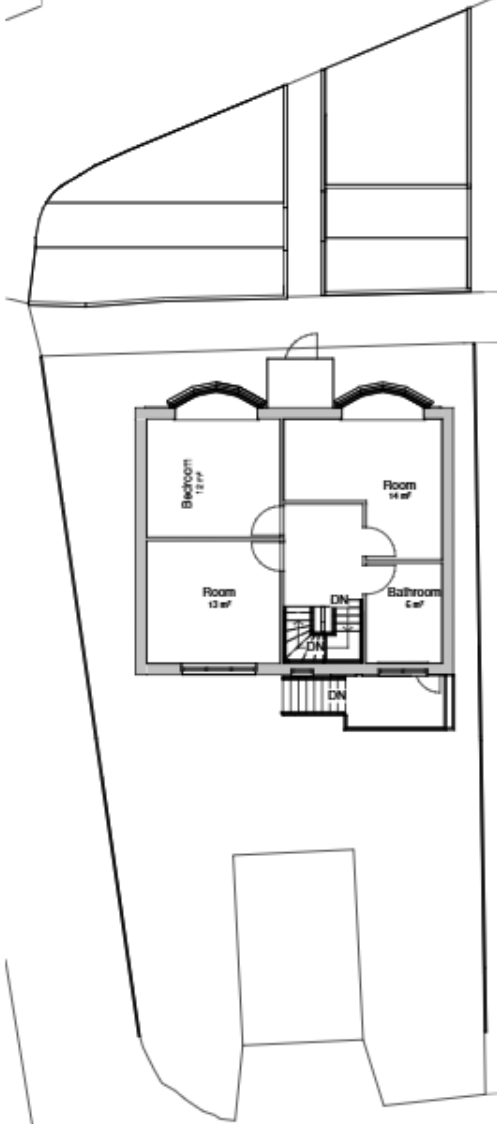

Proposed First Floor
1 : 100

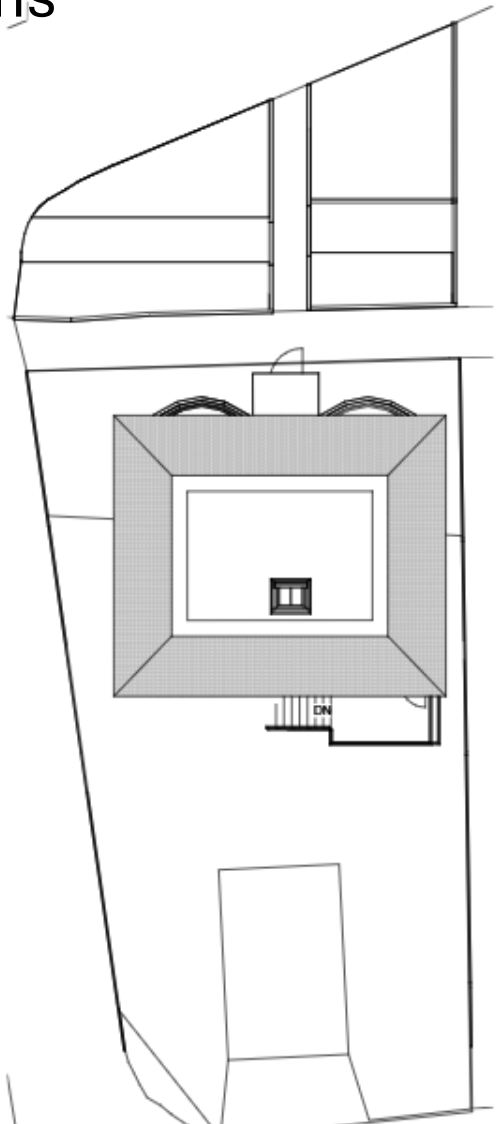

Proposed Loft Plan
1 : 100

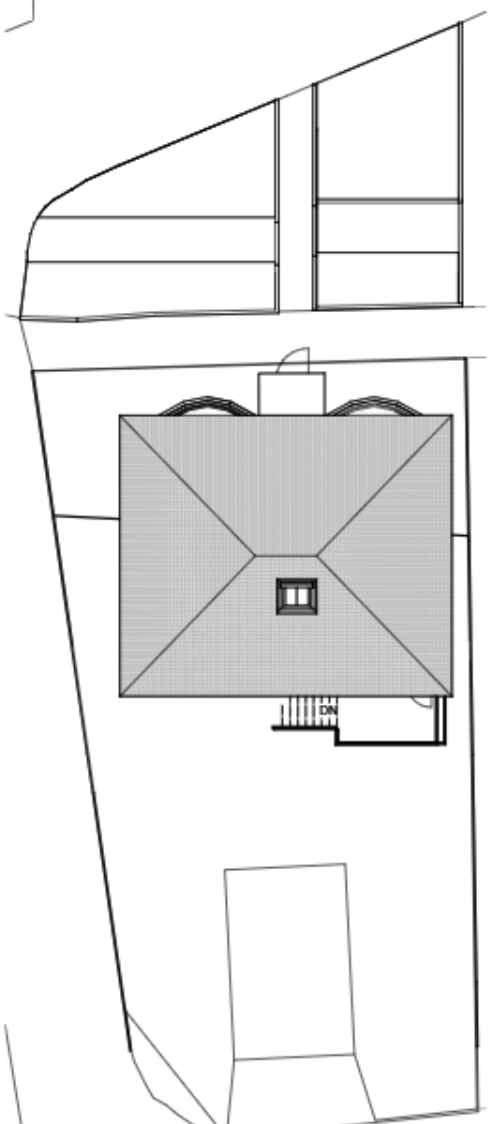

Proposed Roof Plan
1 : 100

Proposed Floor & Roof Plans

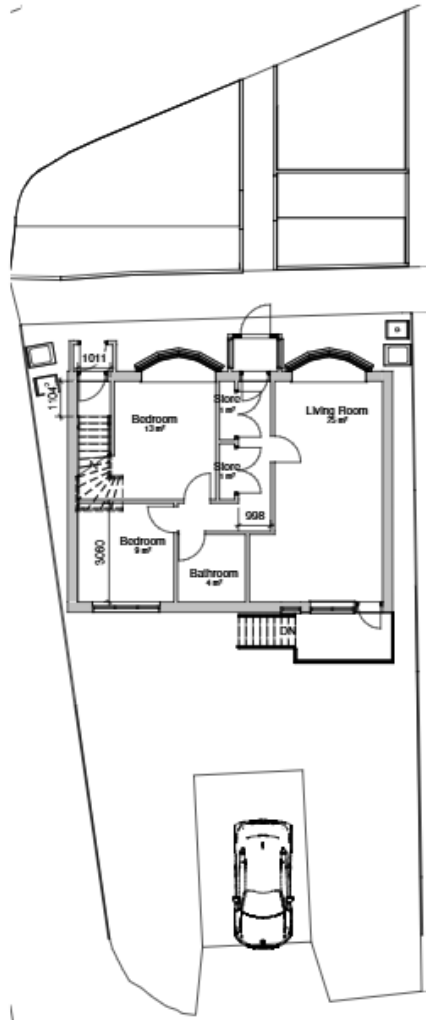

Proposed Ground Floor
1 : 100

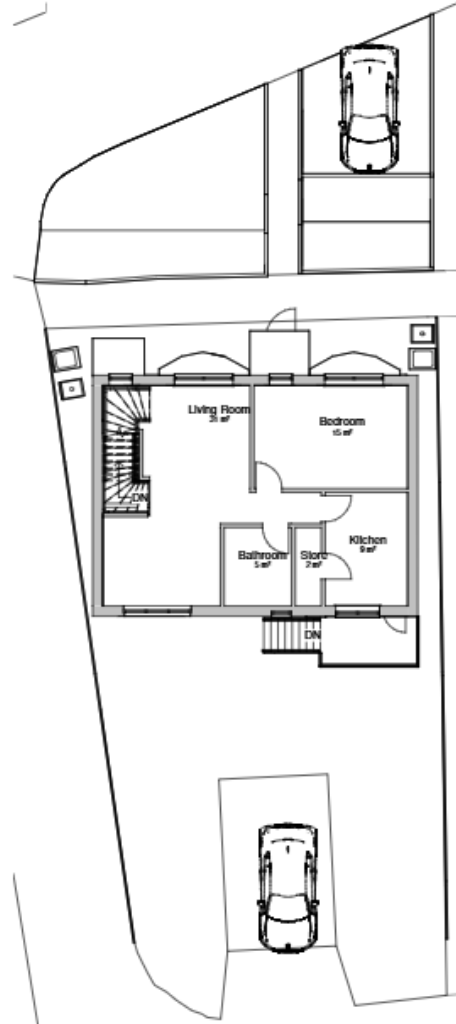

Proposed First Floor
1 : 100

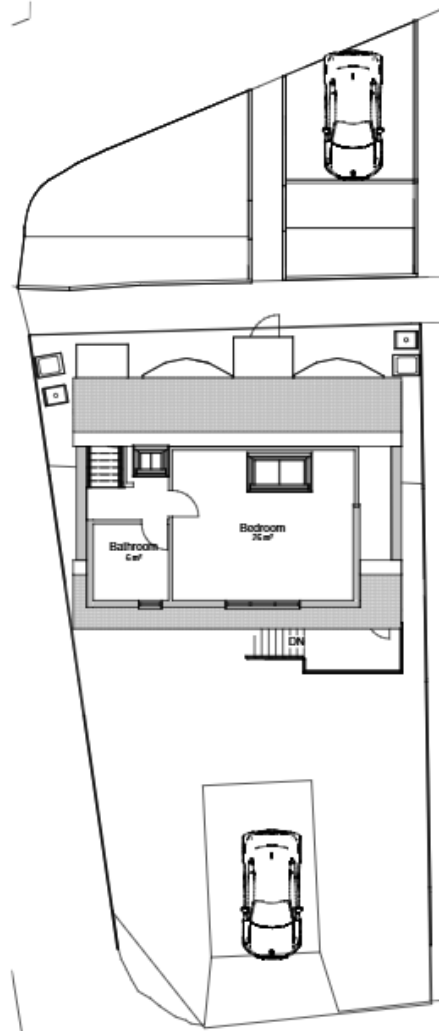

Proposed Loft Plan
1 : 100

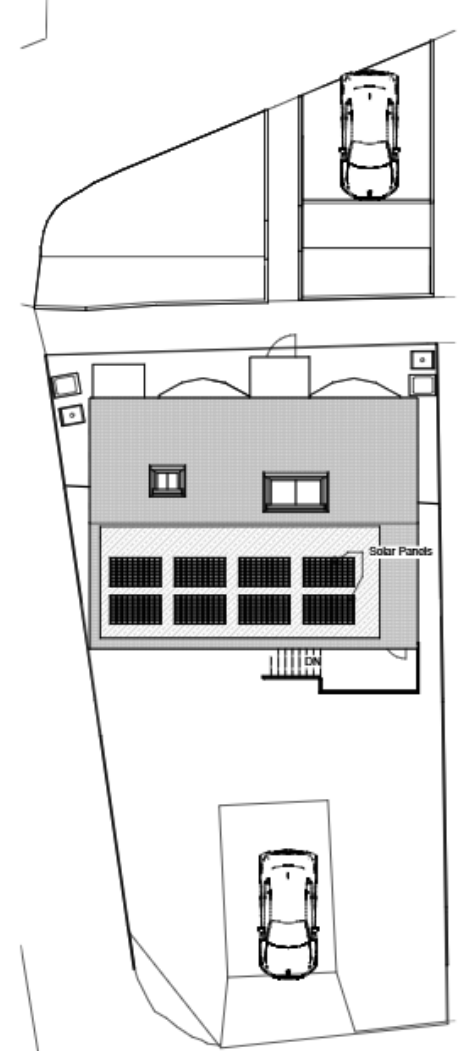

Proposed Roof Plan
1 : 100

Existing Front & Rear Elevations

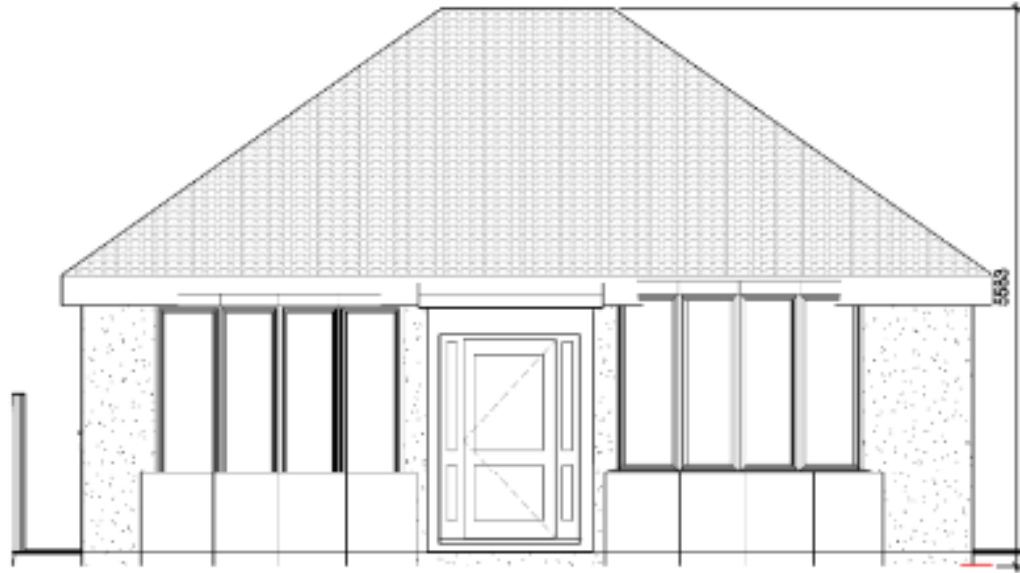

Existing Front Elevation

1 : 50



Existing Rear Elevation

1 : 50

Existing Side Elevations



Existing West Side Elevation
1 : 50

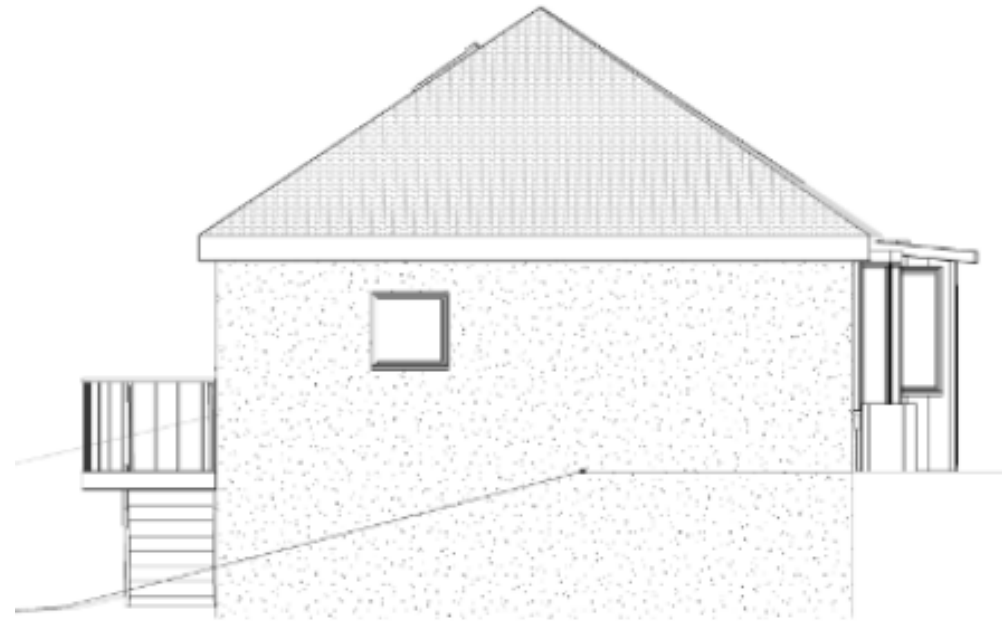

Existing East Side Elevation
1 : 50

MC/25/2534 – Previously Approved Front & Rear Elevations



Proposed Front Elevation
1 : 50



Proposed Rear Elevation
1 : 50

MC/25/2534 – Previously Approved Side Elevations

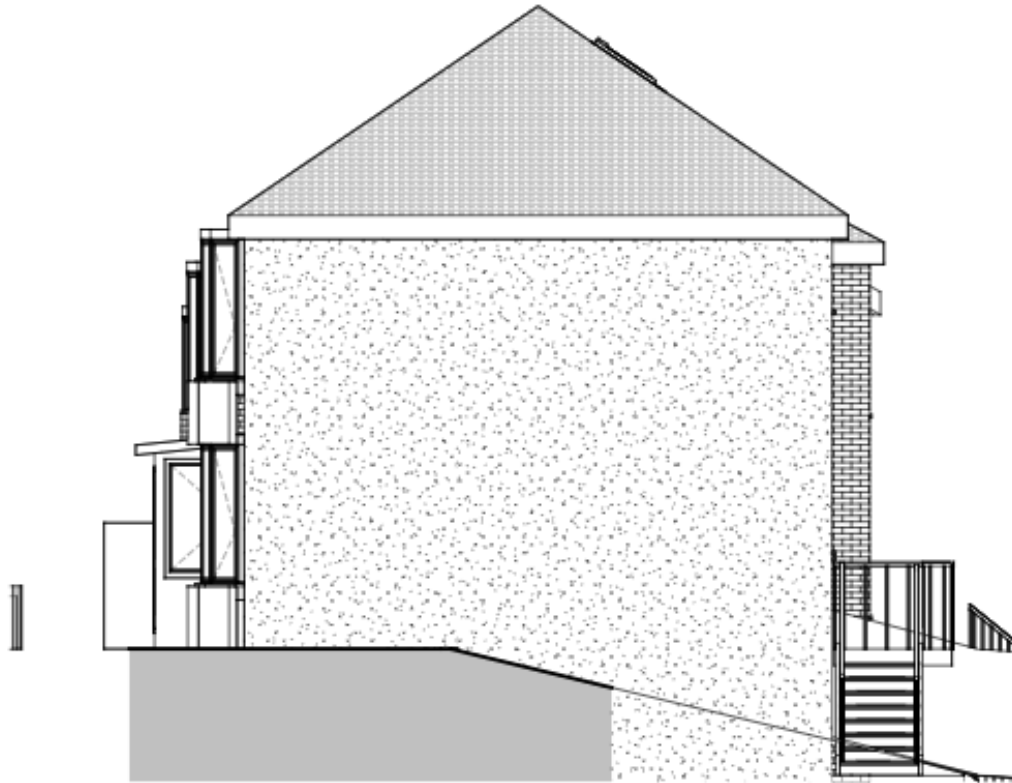

Proposed West Side Elevation
1 : 50

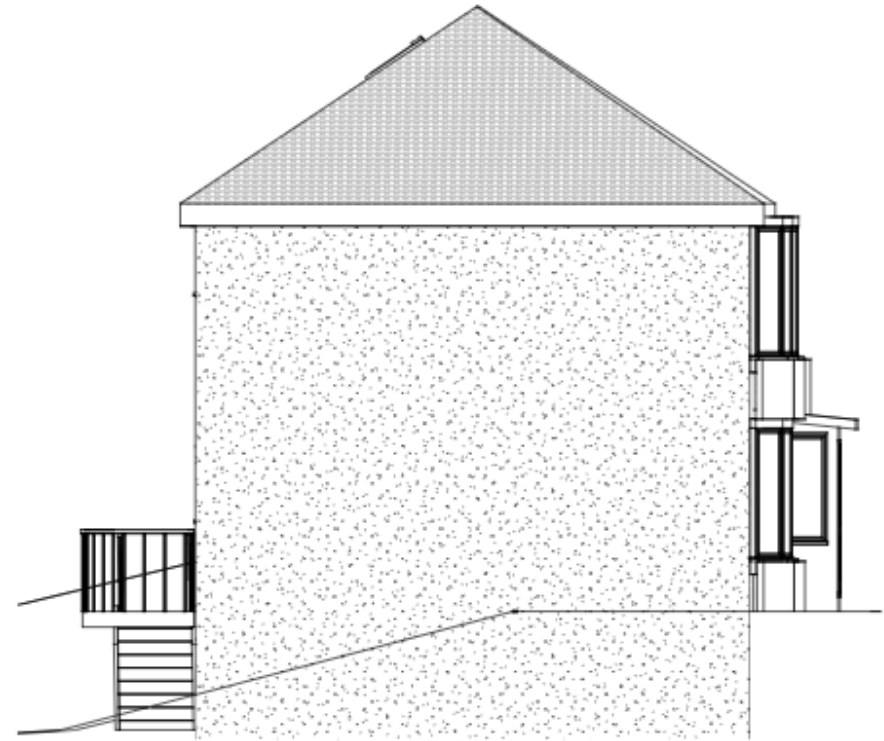

Proposed East Side Elevation
1 : 50

Proposed Front & Rear Elevations



Proposed Front Elevation
1 : 50



Proposed Rear Elevation
1 : 50

Proposed Side Elevations

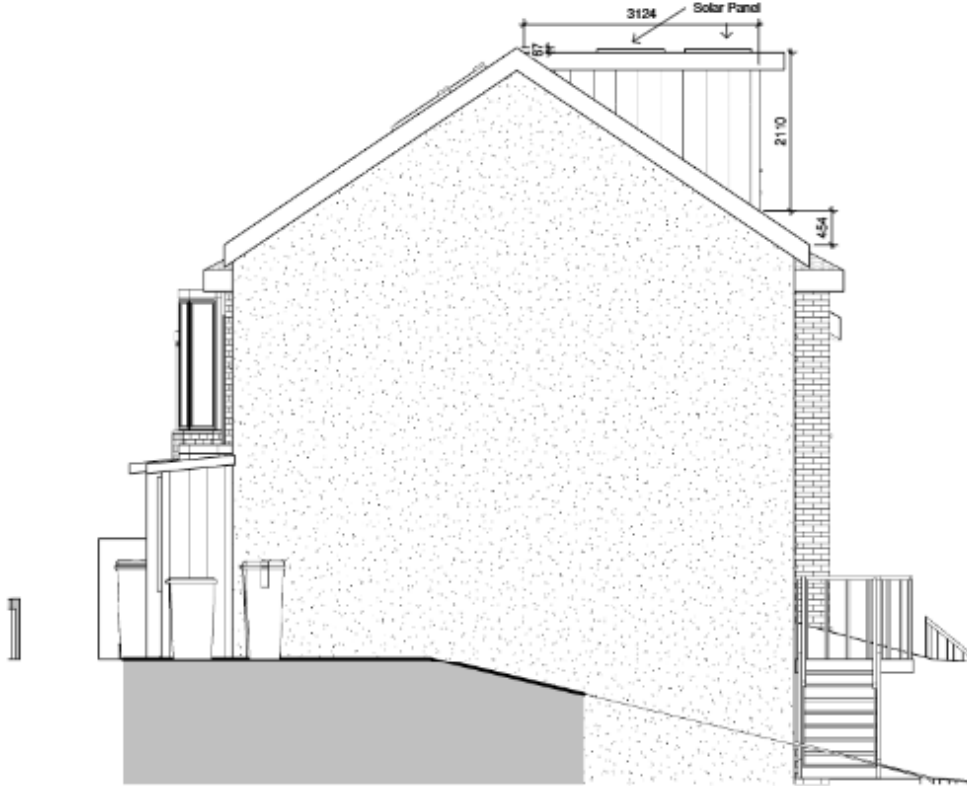

Proposed West Side Elevation
1 : 50

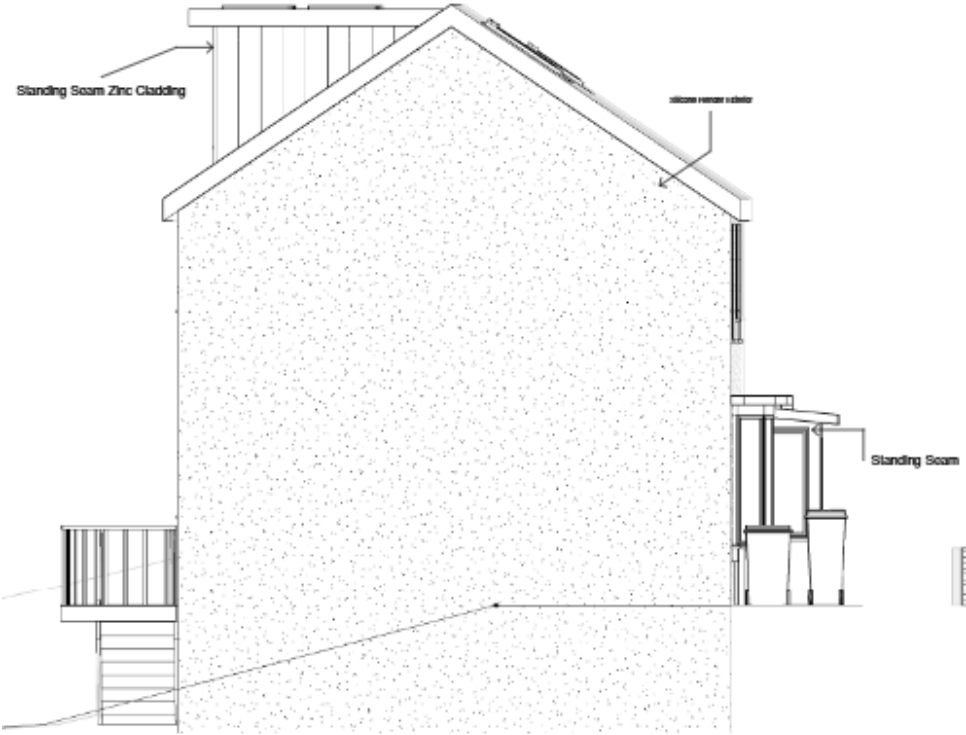

Proposed East Side Elevation
1 : 50

Existing & Proposed Street Scene



Existing Front Elevation View - Perspective
1 : 100



Existing Elevation View - Perspective
1 : 100



Proposed Front Elevation View - Perspective
1 : 100

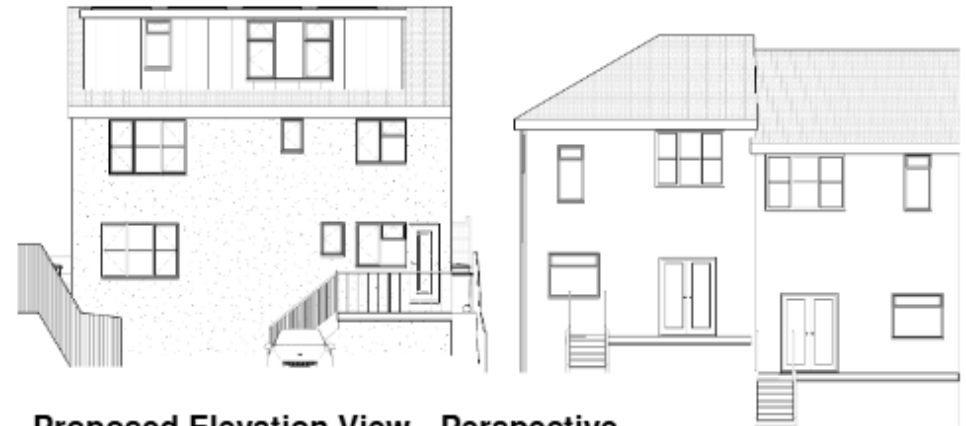

Proposed Elevation View - Perspective
1 : 100

View from Castle Avenue



98 Howard
Avenue